

**ACTA  
TECHNICA  
CORVINIENSIS**

**BULLETIN OF  
ENGINEERING**



*fascicule 4*  
[ October - December ]  
**TOME II** [2009]



***ACTA TECHNICA CORVINIENSIS***

***– Bulletin of Engineering***

***copyright © UNIVERSITY POLITEHNICA TIMISOARA***

***FACULTY OF ENGINEERING HUNEDOARA***

***5, REVOLUTIEI***

***331128 – HUNEDOARA***

***ROMANIA***

***<http://acta.fih.upt.ro>***

***Scientific supplement of***

***ANNALS of FACULTY ENGINEERING HUNEDOARA***

***– INTERNATIONAL JOURNAL of ENGINEERING***

***ISSN: 1584-2665 [print]***

***ISSN: 1584-2673 [CD-Rom]***

***copyright © UNIVERSITY POLITEHNICA TIMISOARA***

***FACULTY OF ENGINEERING HUNEDOARA***

***5, REVOLUTIEI***

***331128 – HUNEDOARA***

***ROMANIA***

***<http://annals.fih.upt.ro>***



---

## **EDITORIAL BOARD**

---

---

### ■ **MANAGER**

**IMRE KISS**

University Politehnica TIMISOARA,  
Faculty of Engineering – HUNEDOARA  
- ROMANIA -

---

### ■ **EDITORS from ROMANIA:**

**VASILE GEORGE CIOATĂ**

University Politehnica TIMISOARA,  
Faculty of Engineering – HUNEDOARA

**VASILE ALEXA**

University Politehnica TIMISOARA,  
Faculty of Engineering – HUNEDOARA

**SORIN AUREL RAȚIU**

University Politehnica TIMISOARA,  
Faculty of Engineering – HUNEDOARA

**DANIEL OSTOIA**

University Politehnica TIMISOARA,  
Faculty of Mechanical Engineering – TIMISOARA

**SORIN TIBERIU BUNGESCU**

Banat's University of Agricultural Sciences and  
Veterinary Medicine TIMISOARA – Department of  
Agricultural Machines – TIMISOARA

**SIMONA DZITAC**

University of ORADEA,  
Faculty of Energy Engineering – ORADEA

**MIRELA SOHACIU**

University Politehnica BUCURESTI, Faculty of  
Materials Science and Engineering – BUCURESTI

---

### ■ **REGIONAL EDITORS FROM HUNGARY**

**TAMÁS HARTVÁNYI**

Széchenyi István University,  
Department of Logistics & Forwarding – GYŐR

**ZSOLT CSABA JOHANYÁK**

College of KECSKEMET, Faculty of Mechanical  
Engineering and Automation – KECSKEMET

**JOZSEF SÁROSI**

Department of Technical and Process Engineering,  
University of SZEGED, Faculty of Engineering – SZEGED

**SÁNDOR BESZEDES**

Department of Technical & Process Engineering,  
University of SZEGED, Faculty of Engineering – SZEGED

**PÉTER TELEK**

University of MISKOLC, Faculty of Mechanical  
Engineering and Information Science – MISKOLC

**PÉTER FÖLDESI**

Széchenyi István University,  
Department of Logistics & Forwarding – GYŐR

**CSABA VÁGVÖLGYI**

Department Of Microbiology, University Of SZEGED,  
Faculty of Science and Informatics – SZEGED

**GERGELY DEZSŐ**

College of NYÍREGYHÁZA, Engineering and  
Agriculture Faculty – NYÍREGYHÁZA

---

### ■ **REGIONAL EDITORS FROM SERBIA**

**ZORAN ANISIC**

University of NOVI SAD  
Faculty of Technical Sciences – NOVI SAD

**MILAN RACKOV**

University of NOVI SAD  
Faculty of Technical Sciences – NOVI SAD

**MAŠA BUKUROV**

University of NOVI SAD  
Faculty of Technical Sciences – NOVI SAD

---

■ **REGIONAL EDITORS FROM SLOVAKIA**

**TIBOR KRENICKÝ**

*Technical University of KOŠICE,  
Faculty of Manufacturing Technologies – PREŠOV*

**MARIAN FLIMEL**

*Technical University of KOŠICE,  
Faculty of Manufacturing Technologies – PREŠOV*

**PETER KOŠTÁL**

*Slovak University of Technology in BRATISLAVA,  
Faculty of Materials Science & Technology – TRNAVA*

**JOZEF DOBRANSKY**

*Technical University of KOŠICE,  
Faculty of Manufacturing Technologies – PREŠOV*

---

■ **REGIONAL EDITORS FROM BULGARIA**

**ANGEL ZUMBILEV**

*Technical University of SOFIA, Department of  
Material Science and Technology – PLOVDIV*

**KRASIMIR IVANOV TUJAROV**

*"Angel Kanchev" University of ROUSSE,  
Faculty of Agricultural Mechanisation – ROUSSE*

---

■ **REGIONAL EDITORS FROM AUSTRALIA**

**JAROMIR AUDY**

*Edith Cowan University in PERTH  
Faculty of Regional Professional Studies, South West – BUNBURY*

---

■ **REGIONAL EDITORS FROM MALAYSIA**

**ABDELNASER OMRAN**

*Environmental Management and Engineering, School of Housing, Building and Planning  
Universiti Sains Malaysia – PULAU PINANG*



## SCIENTIFIC COMMITTEE

### MEMBERS FROM SLOVAKIA

**STEFAN NIZNIK**

Technical University of KOSICE, Faculty of Metallurgy,  
Department of Materials Science – KOSICE

**KAROL VELISEK**

Slovak University of Technology in BRATISLAVA,  
Faculty of Materials Science and Technology – TRNAVA

**VLADIMIR MODRAK**

Technical University of KOSICE,  
Faculty of Manufacturing Technologies – PRESOV

**JOZEF NOVAK-MARCINCIN**

Technical University of KOSICE,  
Faculty of Manufacturing Technologies – PRESOV

**IMRICH KISS**

Institute of Economic & Environmental Security,  
University of Security Management – KOŠICE

**STANISLAV FABIAN**

Technical University of KOŠICE,  
Faculty of Manufacturing Technologies – PREŠOV

**JURAJ SPALEK**

University of ZILINA, Faculty of  
Electrical Engineering – ZILINA

**MICHAL HAVRILA**

Technical University of KOSICE,  
Faculty of Manufacturing Technologies – PRESOV

**TIBOR KVAČKAJ**

Technical University KOŠICE,  
Faculty of Metallurgy – KOŠICE

**EUDOVÍT KOLLÁTH**

Slovak University of Technology in BRATISLAVA,  
Institute of Manufacturing Systems – BRATISLAVA

**MIROSLAV BADIDA**

Technical University of KOŠICE,  
Faculty of Mechanical Engineering – KOŠICE

**MIROSLAV RIMÁR**

Technical University of KOŠICE,  
Faculty of Manufacturing Technologies – PREŠOV

### MEMBERS FROM HUNGARY

**BÉLA ILLÉS**

University of MISKOLC, Faculty of Mechanical  
Engineering and Information Science – MISKOLC

**IMRE J. RUDAS**

BUDAPEST University of Technology and Economics,  
Department of Structural Engineering – BUDAPEST

**TAMÁS KISS**

University of SZEGED, Department of Inorganic  
and Analytical Chemistry – SZEGED

**TAMÁS ENDRÓDY**

Department of Technical & Process Engineering,  
University of SZEGED, Faculty of Engineering – SZEGED

**IMRE DEKÁNY**

University of SZEGED, Department  
of Colloid Chemistry – SZEGED

**CECILIA HODUR**

University of SZEGED, College Faculty  
of Food Engineering – SZEGED

**FERENCZ ARPAD**

College of KECSKEMÉT, Faculty of Horticulture,  
Department of Economics – KECSKEMÉT

**ANDRÁS BAKÓ**

Széchenyi István University,  
Department of Logistics & Forwarding – GYŐR

### MEMBERS FROM POLAND

**LESZEK A. DOBRZANSKI**

Silesian University of Technology – GLIWICE  
Institute of Engineering Materials and Biomaterials

**STANISŁAW LEGUTKO**

Institute of Mechanical Technology,  
Polytechnic University – POZNAN

**ANDRZEJ WYCISLIK**

Silesian University of Technology in KATOWICE,  
Faculty of Materials Science and Metallurgy –  
KATOWICE

**MEMBERS FROM SERBIA****SINISA KUZMANOVIC**

University of NOVI SAD  
Faculty of Technical Sciences – NOVI SAD

**MIRJANA VOJINOVIĆ MILORADOV**

University of NOVI SAD,  
Faculty of Technical Sciences – NOVI SAD

**VLADIMIR KATIC**

University of NOVI SAD,  
Faculty of Technical Sciences – NOVI SAD

**MIROSLAV PLANČAK**

University of NOVI SAD,  
Faculty of Technical Sciences – NOVI SAD

**MILOSAV GEORGIJEVIC**

University of NOVI SAD,  
Faculty of Engineering – NOVI SAD

**DAMIR KAKAS**

University of NOVI SAD,  
Faculty of Technical Sciences – NOVI SAD

**MEMBERS FROM PORTUGAL****JOÃO PAULO DAVIM**

University of AVEIRO  
Department of Mechanical Engineering – AVEIRO

**MEMBERS FROM CROATIA****DRAZAN KOZAK**

Josip Juraj Strossmayer University of OSIJEK,  
Mechanical Engineering Faculty – SLAVONKI BROAD

**BRANIMIR BARISIC**

University of RIJEKA, Department of Production  
Engineering, Faculty of Engineering – RIJEKA

**MILAN KLJAJIN**

Josip Juraj Strossmayer University of OSIJEK,  
Mechanical Engineering Faculty – SLAVONKI BROAD

**MEMBERS FROM ROMANIA****STEFAN MAKSAY**

University Politehnica TIMISOARA,  
Faculty of Engineering HUNEDOARA

**FRANCISC WEBER**

University Politehnica TIMISOARA,  
Faculty of Engineering – HUNEDOARA

**IOAN MARGINEAN**

University Politehnica BUCURESTI, Faculty of Materials  
Science and Engineering – BUCURESTI

**JULIAN RIPOSAN**

University Politehnica BUCURESTI, Faculty of Materials  
Science and Engineering – BUCURESTI

**VICTOR BUDĂU**

University Politehnica TIMIȘOARA  
Faculty of Mechanical Engineering – TIMIȘOARA

**IOAN LAZA**

University Politehnica TIMIȘOARA  
Faculty of Mechanical Engineering – TIMIȘOARA

**MIHAI CHIȘAMERA**

University Politehnica BUCURESTI, Faculty of Materials  
Science and Engineering – BUCURESTI

**AUREL CRIȘAN**

University Transilvania of BRASOV, Faculty of Material  
Science and Engineering – BRĂȘOV

**TEODOR HEPUT**

University Politehnica TIMISOARA,  
Faculty of Engineering HUNEDOARA

**MIRCEA BEJAN**

Technical University of CLUJ-NAPOCA  
Faculty of Mechanical Engineering – CLUJ-NAPOCA

**IOAN VIDA-SIMITI**

Technical University of CLUJ-NAPOCA, Faculty of  
Materials Science and Engineering – CLUJ-NAPOCA

**VASILE MIREA**

University Politehnica BUCURESTI, Faculty of  
Materials Science and Engineering – BUCURESTI

**CRISTIAN PREDESCU**

University Politehnica BUCURESTI, Faculty of  
Materials Science and Engineering – BUCURESTI

**CARMEN ALIC**

University Politehnica TIMIȘOARA,  
Faculty of Engineering – HUNEDOARA

**CSABA GYENGE – ROMANIA**

Technical University of CLUJ-NAPOCA,  
Machine Building Faculty – CLUJ-NAPOCA

**ADALBERT KOVÁCS**

University Politehnica TIMISOARA,  
Department of Mathematics – TIMISOARA

---

■ **MEMBERS FROM BULGARIA**

---

**NIKOLAY MIHAILOV**

*Anghel Kanchev University of ROUSSE, Faculty of Electrical and Electronic Engineering – ROUSSE*

**KRASSIMIR GEORGIEV**

*Institute of Mechanics, Department of Mechatronic Systems, Bulgarian Academy of Sciences – SOFIA*

---

**HRISTO BELOEV**

*Anghel Kanchev University of ROUSSE, Faculty of Electrical and Electronic Engineering – ROUSSE*

**VELIZARA IVANOVA PENCHEVA**

*Anghel Kanchev University, Faculty of Electrical and Electronic Engineering – ROUSSE*

---

■ **MEMBERS FROM GREECE**

---

**GIORGIOS PETROPOULOS**

*University of THESSALY, Department of Mechanical and Industrial Engineering – VOLOS*

---

■ **MEMBERS FROM INDIA**

---

**SUGATA SANYAL**

*School of Technology & Computer Science  
Tata Institute of Fundamental Research – MUMBAI*

---

■ **MEMBERS FROM ARGENTINA**

---

**GREGORIO PERICHINSKY**

*University of BUENOS AIRES,  
Faculty of Engineering – BUENOS AIRES*

---

■ **MEMBERS FROM CZECH REPUBLIC**

---

**VLADIMIR ZEMAN**

*Department of Mechanics, Faculty of Applied Sciences, University of West Bohemia – PILSEN*

**IMRICH LUKOVICS**

*Department of Production Engineering, Faculty of Technology, Tomas Bata Univerzity – ZLÍN*

---

**JAN VIMMR**

*Department of Mechanics, Faculty of Applied Sciences, University of West Bohemia – PILSEN*

**Ivo SCHINDLER**

*Technical University of OSTRAVA, Faculty of Metallurgy and Materials Engineering – OSTRAVA*

---

■ **MEMBERS FROM BRAZIL**

---

**ALEXANDRO MENDES ABRÃO**

*Universidade Federal de MINAS GERAIS  
Escola de Engenharia – BELO HORIZONTE*

---

**MÁRCIO BACCI DA SILVA**

*Universidade Federal de UBERLÂNDIA  
Engenharia Mecânica – UBERLÂNDIA*

---

■ **MEMBERS FROM BOSNIA & HERZEGOVINA**

---

**TIHOMIR LATINOVIC**

*University in BANJA LUKA,  
Faculty of Mechanical Engineering – BANJA LUKA*

---

■ **MEMBERS FROM FRANCE**

---

**BERNARD GRUZZA**

*Universite Blaise Pascal CLERMONT-FERRAND,  
Institut des Sciences de L'Ingenieur (CUST) –  
CLERMONT-FERRAND*

---

■ **MEMBERS FROM ITALY**

---

**ALESSANDRO GASPARETTO**  
*University of UDINE*  
*Faculty of Engineering – UDINE*

---

■ **MEMBERS FROM CUBA**

---

**NORGE I. COELLO MACHADO**  
*Universidad Central "Marta Abreu" de LAS VILLAS,*  
*Faculty of Mechanical Engineering, SANTA CLARA*

---

■ **MEMBERS FROM AUSTRIA**

---

**BRANKO KATALINIC**  
*VIENNA University of Technology,*  
*Institute of Production Engineering – VIENNA*

---

■ **MEMBERS FROM MOROCCO**

---

**SAAD BAKKALI**  
*Abdelmalek Essaâdi University*  
*Faculty of Sciences and Techniques – TANGIER*

---

■ **MEMBERS FROM MACEDONIA**

---

**VALENTINA GECEVSKA**  
*University "St. Cyril and Methodius"*  
*Faculty of Mechanical Engineering – SKOPIE*

---



**ACTA TECHNICA CORVINIENSIS**  
**– BULLETIN of ENGINEERING**

Copyright ©

**UNIVERSITY POLITEHNICA TIMISOARA**  
**FACULTY OF ENGINEERING HUNEDOARA**  
**5, REVOLUTIEI**  
**331128 – HUNEDOARA**  
**ROMANIA**

<http://acta.fih.upt.ro>



**ACTA TECHNICA CORVINIENSIS – BULLETIN OF ENGINEERING.  
FASCICULE 4 [OCTOBER – DECEMBER]. TOME II. 2009**

1. *LUDMILA BRICHTOVÁ, RADIM ŠUBERT*  
**ALTERNATIVE WAYS OF TEXTILE MATERIALS MOUNTING WHILE USING  
MICROWAVE FIELD** 13

■ **Abstract:**

*This work analyses possibility of using microwave energy for small textile parts mounting. Existing ways of textile materials mounting are dependent on temperature, pressure and humidity, whereas energy intensity of this process is very high. Using of microwave field can decrease energy intensity, but it is necessary to find optimal values of parameters for particular material types – it means temperature, humidity, mounting time and apparatus power. At these conditions should be reached high quality of bonded joint.*

2. *PIOTR CZECH, PIOTR FOLEGA, GRZEGORZ WOJNAR*  
**EVALUATION OF INFLUENCE OF CRACKING GEAR-TOOTH ON CHANGES ITS  
STIFFNESS** 17

■ **Abstract:**

*In this paper the research results are shown which were to mark the influence of the cracking in the base of the tooth of wheel on the change of the wheel rigidity. In order to achieve this, a series of experiments was conducted with the use of models FEM and BEM. The correctness of the models was verified with the use of analytic method, whereas the final results were confirmed in a research experiment conducted on the endurance machine MTS. The achieved results enabled the conduction of research devoted to the possibility of use of simulation models of toothed gears to get the teaching data for artificial neural networks. The networks taught on the basis of such data would in consequence serve to be exploited on data coming from the real toothed gears.*

3. *IVANA DOSEDĚLOVÁ*  
**DETERMINATION OF SEWN SEAM IMPACT STRENGTH** 23

■ **Abstract:**

*This article defines strength as the fundamental function property of the seam which characterizes possibilities of using of technical ready-made products. Strength is the force which the seam resists. There are presented the measuring methods of seam strength in dependence on the method of strain. According to the method of strain the seams have to resist the forces which act quasi statically or at impact. It is necessary to differentiate and define impact strength and to know how to measure it.*

4. STANISLAV FABIAN

**QUANTIFICATION AND ANALYSIS OF TECHNOLOGICAL PARAMETERS RELEVANCE IN CONTINUITY WITH CUT AREA QUALITY**

27

■ **Abstract:**

*Manufacturing system production quality with technology AWJ is influenced by various factors. Important influence has on it also technological parameters set of manufacturing systems from those every in other range and to it corresponding importance influences quality and working cost in manufacturing systems. The article busies with manufacturing systems with technology AWJ and technological parameters influence on cut area quality at cutting steels HARDOX. The article presents the results of experimental research technological parameters influence. In the article the principles and recommends for firms that perform working manufacturing systems with technology AWJ are also formulated.*

5. MÁRIO GAJDOŠ, JOZEF JURKO

**THE PLOUGHING EFFECT AT DRILLING OF THEIR INFLUENCE ON THE PRODUCTION OF HOLES**

31

■ **Abstract:**

*Automated production has characteristic features: a reduction of production costs, stimulation of the development of cutting tools, and changes in the construction of machine tools, all of which work against the creation of optimal technological methods, which thrusts the technological process of cutting into a more important position. These trends confirm that the cutting process remains one of the basic manufacturing technologies. This article presents the results of experiments that concerned the verification of tool wear and special "Ploughing effect" on the cutting tool of workpieces of difference types of austenitic stainless steel. The paper present of real experimental results. The authors would like to thank in words the KEGA grant agency at the Ministry of Education SR for supporting research work and co-financing the projects: Grant work KEGA #3/7166/2009.*

6. LUBOŠ KOTEK

**DEPENDABILITY, SAFETY AND IMPACT OF HUMAN FACTOR**

35

■ **Abstract:**

*Effective management of task dependability and safety is the necessity of a successful operation of any manufacturing system. No one wants faults to happen, but these events sometimes happen. It is one of the reasons, why engineering work on manufacturing system goes beyond ordinary maintenance and constitutes modification. Such modification involves a change in the plant or process and can introduce a wasting of wherewithal or can cause risks. At the moment, a lot of problematic areas are encountered during risk evaluation. In this contribution attention is paid to identification and selection of risk and analysis of human factor.*

7. RADOSLAV KREHEL, JOZEF DOBRÁNSKY, TIBOR KRENICKÝ

**MATHEMATICAL MODEL OF TECHNOLOGICAL PROCESSES WITH PREDICTION OF OPERATING DETERMINING VALUE**

39

■ **Abstract:**

*The paper describes a development of a new approach to simulation of dimensional wear of cutting tool with subsequent element of correction in limits of parametrically given optimal shifts. The articel describes aspect belonging to polynomic transformation of experimentally given discrete values of knife point position and their subsequent integrity into continuous funtional form compatibile with used software.*

8. VILÉM MÁDR, RADIM UHLÁŘ, LIBOR M. HLAVÁČ, LIBOR SITEK, JOSEF FOLDYNA,  
RUDOLF HELA, LENKA BODNÁROVÁ, JIŘÍ KALIČINSKÝ  
**HIGH-VELOCITY WATER JET IMPACT ON CONCRETE SAMPLES**

43

■ **Abstract:**

The concrete samples with various erosion states were disintegrated inside the overpressure vessel using high-velocity water jet and depth of penetration was measured. Removing of the eroded parts of samples was also tested using low-pressure generated continuous or pulsing fan jets and rotating jets. The influence of the erosion states, water jet techniques, traverse rate and stand-off distance on the disintegration volume was studied and the surface topography was investigated. The high-pressure generated continuous water jet was applied in the overpressure vessel used for simulation of pressures equivalent to the submersion to several depths under the water level. The low-pressure generated continuous or pulsing jets were applied in air conditions. Some samples of special decorative concretes were also studied.

9. DAVIDE BIOLGHINI, JOZEF NOVÁK-MARCINČIN, ROBERT ČEP  
**PROJECT INTER-COUNTRIES RESEARCH FOR MANUFACTURING ADVANCEMENT (IRMA)**

49

■ **Abstract:**

The project Inter-countries Research for Manufacturing Advancement (IRMA) is focused to the realization of a research and comparative analysis in the 27 European Union's member states, aimed at promotion of excellence and efficiency of the instruction in higher education institutions. The IRMA project is research on the manufacturing engineering field, taken into consideration its high level of innovation and fast changes in requirements that students must possess, in order to be adapt and competitive on the labour market. The objectives of the IRMA project is to innovate and to improve educational systems of technical universities at European level, in order to offer to students a competitive environment based on innovative teaching methods, instruments and contents.

10. MICHAL PETRŮ, JAN PETŘÍK  
**SYSTEMS TO OPTIMIZE COMFORT AND DEVELOPMENTS OF CAR SEAT**

55

■ **Abstract:**

In this work are presented the types of amplifier stages with field-effect transistors, as well as the diagrams of the low-signal amplifiers achieved with TEC-J for the three connection types: common-source, common-grid and common-drain. Also, using the EWB-Multisim 8 program, it was simulated the operation of the amplifier with TEC-J in common-source connection, the amplifier with TEC-MOS in common-drain connection and the cascode amplifier with two TEC-J transistors.

- \*\* **JOURNAL – ANNALS OF FACULTY ENGINEERING HUNEDOARA – INTERNATIONAL JOURNAL of ENGINEERING. TOME 8 (2009)**

61

- \*\* **SCIENTIFIC EVENT – VII<sup>th</sup> INTERNATIONAL CONGRESS "MACHINERY, TECHNOLOGY, MATERIALS" – INNOVATIONS FOR THE INDUSTRY**

65

- \*\* **SCIENTIFIC EVENT – 3<sup>RD</sup> INTERNATIONAL CONFERENCE FOR ENTREPRENEURSHIP, INNOVATION AND REGIONAL DEVELOPMENT – ICEIRD 2010**

67

- \*\* **SCIENTIFIC EVENT – THE XI<sup>th</sup> INTERNATIONAL SYMPOSIUM "YOUNG PEOPLE AND MULTIDISCIPLINARY RESEARCH" – ISYPMR 2009**

73

**\*\* THE 3<sup>RD</sup> KUWAIT WASTE MANAGEMENT CONFERENCE & EXHIBITION****77****\*\* GUIDELINES FOR PREPARING THE MANUSCRIPTS****81**

*ACTA TECHNICA CORVINIENSIS – Bulletin of Engineering, Fascicule 4 [October-December] is a volume dedicated to THE 9<sup>TH</sup> INTERNATIONAL SCIENTIFIC CONFERENCE – NEW TRENDS IN TECHNICAL SYSTEMS OPERATION 2009, organized in Presov, SLOVAKIA.*

*Fascicule 4 [October-December] includes papers which will be presented in the Conference's sections.*

*ACTA TECHNICA CORVINIENSIS – Bulletin of Engineering is an international and interdisciplinary journal which reports on scientific and technical contributions.*

*ACTA TECHNICA CORVINIENSIS – Bulletin of Engineering is a scientific supplement of ANNALS OF FACULTY ENGINEERING HUNEDOARA – JOURNAL OF ENGINEERING.*



## **ALTERNATIVE WAYS OF TEXTILE MATERIALS MOUNTING WHILE USING MICROWAVE FIELD**

### ■ **Abstract:**

*This work analyses possibility of using microwave energy for small textile parts mounting. Existing ways of textile materials mounting are dependent on temperature, pressure and humidity, whereas energy intensity of this process is very high. Using of microwave field can decrease energy intensity, but it is necessary to find optimal values of parameters for particular material types – it means temperature, humidity, mounting time and apparatus power. At these conditions should be reached high quality of bonded joint*

### ■ **Keywords:**

*microwave field, mounting, textile, damp-heat processing*

### ■ **INTRODUCTION**

*Using of microwave energy is in industry generally growing. In textile industry is microwave field being used for drying, cleaning or pigment fixing. Inside the microwave apparatus energy is being transformed into heat, whereas heating up of inserted material is in whole volume, in contrast to conventional heating up, where heat is spreading from surface into material center. It is basic characteristic of microwave field incidence. Regarding these properties it is possible to think over the alternative way of mounting by using of microwave field.*

*At microwave mounting process, appeared heat induces melting of backing inset and inset is consequently bonded with base material. This process is generally dependent on temperature, humidity, microwave device power, microwave length and physical properties of backing and*

*base material. It is necessary to analyze these parameters, to explore extent of their influence and to find their optimal value, so that the final effect can be as good as possible, from both quantitative and qualitative point of view. Using of this technology can bring energy savings in contrast to conventional technology (using mounting presser).*

### ■ **MICROWAVE MOUNTING**

*For microwave mounting was used microwave apparatus with frequency of 2450 MHz, which corresponds to wave length approximately 12,2 cm. Energy absorbed by volume unit [2] is equal to:*

$$P = 2\pi \cdot f \cdot \epsilon' \cdot \epsilon'' \cdot E^2 \quad (1)$$

*P ... energy absorbed by volume unit [W.m<sup>-3</sup>]*

*f ... microwave field frequency [Hz]*

$\epsilon'$  ... permittivity [ $F \cdot m^{-1}$ ]

$\epsilon''$  ... dielectric loss-factor of material

$E$  ... intensity of electric field inside material

Microwave energy is being transformed into heat, which induces melting of backing inset (based on polyamide 6), heating up of base material and finally bonding of both parts. Temperature inside the apparatus should be approx. 225°C, which is polyamide 6 melting temperature. This temperature should be modified according to used base material and its ironing temperature, so that base material is not destructed.

Amount of absorbed energy and consequently mounting quality is strongly dependent on physical qualities of textile material – permittivity, electrical conductibility and humidity receiving ability. Added humidity is an important factor, because material is absorbing microwave energy better if it is containing more water rate (or other polar dissolution reagent).

It is possible to suppose, that joint quality can be improved by load pressure inside the apparatus. It is appropriate to achieve of pressure using ballast weight made of such material, that is transparent toward microwave field, for example glass or teflon.

**EXPERIMENT**

For experimental part of this work was composed set of samples encompassing various types of base material with various physical qualities. Backing inset was based on polyamide, which is most common backing material.

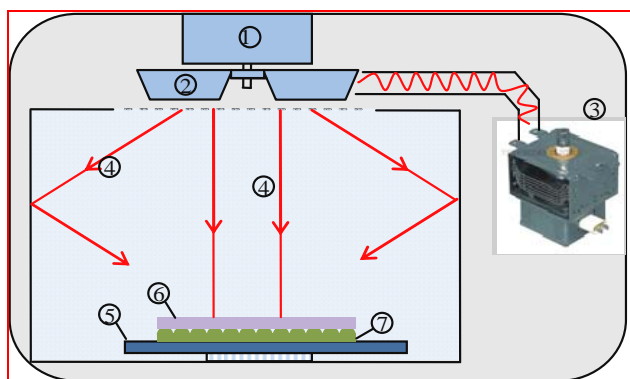

Figure 1: Microwave system

1... motor, 2... apparatus for microwave field (energy) dissipation, 3... magnetron, 4... microwaves, 5... rotating plate, 6... base material, 7... backing material

Base material: 1. 100% polyester

2. 100% linen

3. 40% polyester+60% wool

Mounting backing inset: polyamide point

application – melting temperature 220°C

Constant values: microwave system power – 750W,

microwave frequency – 2450MHz,

pressure – 1kPa

Variable values: operating time – 120-180s

humidity – 0,15-0,60g of added water to 1cm<sup>2</sup>

For better condition specification would be good to have chance to measure inside temperature and to change power of microwave device. Unfortunately at this experiment was not possible to adjust mentioned parameters, because experiment was performed using standard microwave device (microwave oven).

Tab. 1: Measured strength at three type of base material

		100% polyester	100% linen	40% polyester 60%wool
Time [s]	Added water [g·cm <sup>-2</sup> ]	Strength [N]	Strength [N]	Strength [N]
120	0,2	0,000	0,000	0,000
120	0,3	0,181	0,008	0,370
120	0,4	0,779	0,018	0,449
120	0,5	1,410	0,307	0,500
120	0,6	1,533	0,317	0,598
135	0,2	0,000	0,000	0,097
135	0,3	1,028	0,105	0,203
135	0,4	2,227	0,962	0,418
135	0,5	2,605	1,099	0,424
135	0,6	3,005	3,317	0,494
150	0,2	0,000	0,067	0,000
150	0,3	1,137	0,132	0,014
150	0,4	1,781	0,390	0,124
150	0,5	2,319	2,791	0,416
150	0,6	3,011	3,092	0,736
165	0,2	0,000	0,000	0,000
165	0,3	0,147	0,282	0,122
165	0,4	0,894	0,590	0,176
165	0,5	1,097	0,627	0,285
165	0,6	2,818	3,727	0,305
180	0,2	1,070	0,000	0,000
180	0,3	1,097	0,210	0,066
180	0,4	1,881	1,185	0,079
180	0,5	1,920	2,253	0,398
180	0,6	2,682	3,006	0,502

Above mentioned samples were inserted into microwave field at specified variable values (operating time and added water). Consequently

were measured values of strength of bonded joint using dynamometer. Results are stated in tab. 1. The aim was to find optimal input parameters values for reaching of the highest strength of bonded joint without destruction of base material.

Problems of standard microwave device as we were using: inhomogeneity of microwave field (in connection with measurement reproducibility), protection of microwave system against radiation excess and measurement of actual temperature inside the microwave system. On this account presented dependencies is not possible to considerate as exact. They should only show off basic tendencies and trends.

**RESULTS**

For each textile material as described above was prepared 25 samples. And at each sample joint strength was measured using dynamometer. The following graphs describe dependence time – humidity – strength.

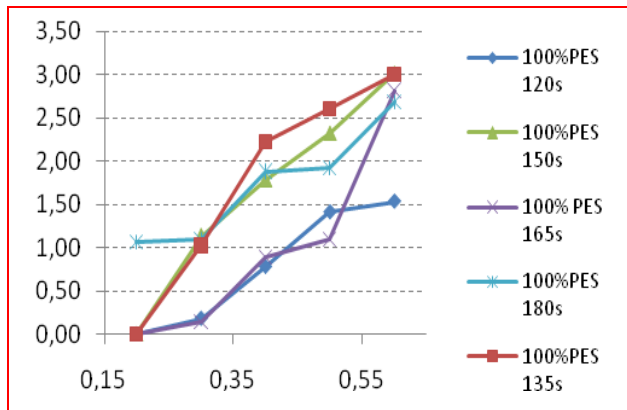

Graph 1: Dependence of strength (y axis) on amount of added water (x axis) for 100% polyester

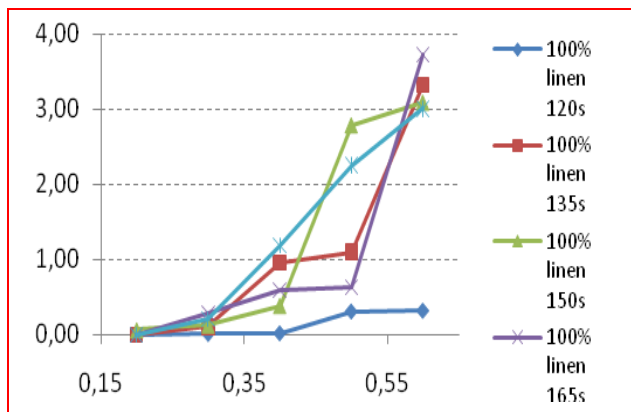

Graph 2: Dependence of strength (y axis) on amount of added water (x axis) for 100% linen

From graphical interpretation it is possible to assume that with increasing time and humidity, strength of bonded joint is increasing as well, whereas increasing intensity is in relation with physical qualities of used material.

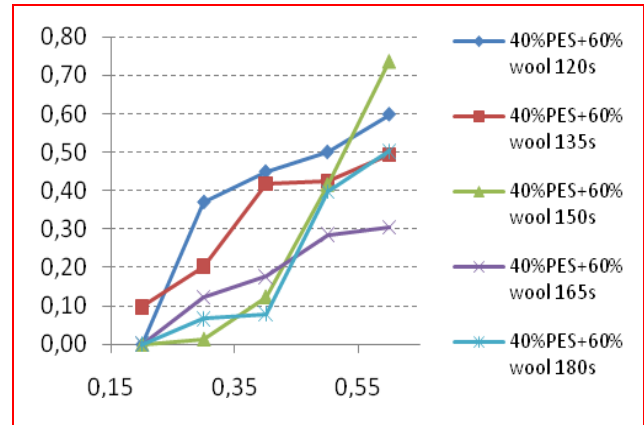

Graph 3: Dependence of strength (y axis) on amount of added water (x axis) for 40% polyester + 60% wool

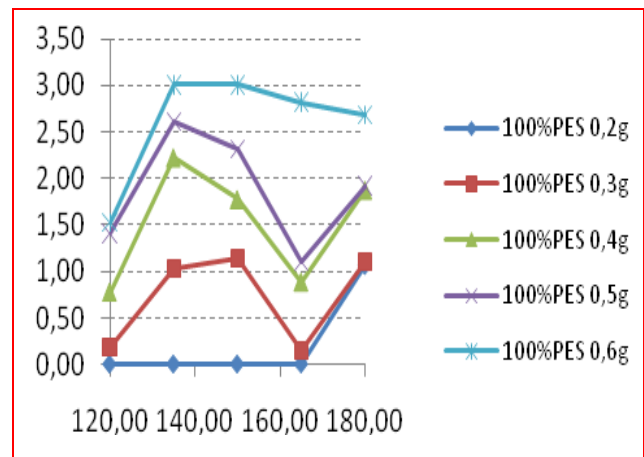

Graph 4: Dependence of strength (y axis) on time (x axis) for 100% polyester

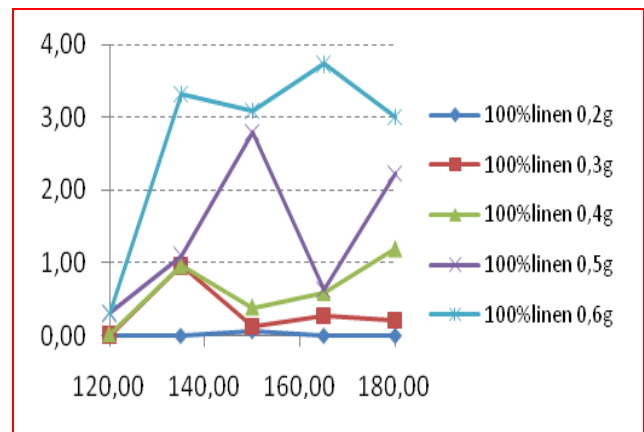

Graph 5: Dependence of strength (y axis) on time (x axis) for 100% linen

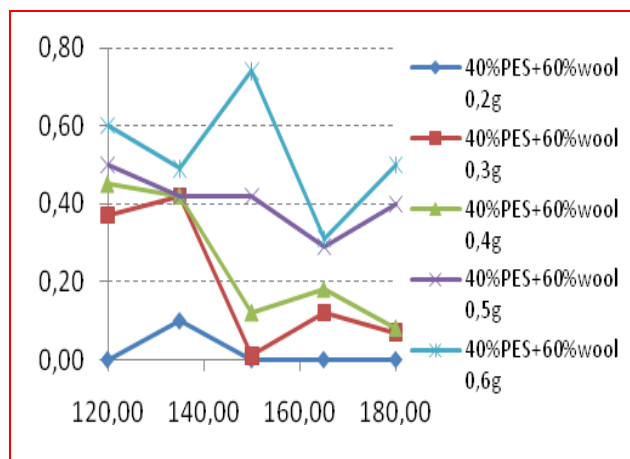

Graph 6: Dependence of strength (y axe) on time (x axe) for 40%polyester+60%wool

### CONCLUSION

For textile parts we realized mounting process in microwave field. Technology of inserting textile parts into microwave device is from its principle primarily determined for mounting of small textile parts.

For larger parts would be possible to use device at present used for microwave drying. Quality of the joint strength depends on material parameters, humidity, temperature, pressure, operating time and system power. In this moment we are able to affect only some of them, so the joint strength is less than joint strength at using conventional presser. From results analysis it is evident, that optimal value of time when samples are under influence of microwave field is in this case 150s. Strength of bonded joint is strongly dependent on amount of added water. The more water is added, the better is the result of mounting process. It is possible to assume that optimal value of added water is close to maximal amount of water that is material and its structure able to absorb. Next experiments for determination of optimal parameters are subject of following research.

### REFERENCES

- [1] MILITKÝ, J. Textile fibres, TU of Liberec, Liberec 2002, Czech republic (in czech language)
- [2] HÁJEK, M. Microwaves in action, Institute of Chemical Process Fundamentals, Academy of sciences of the Czech republic (in czech language)

[3] VRBA, J. Introduction into microwave technics, ČVUT Praha, 1999 (in czech language)

[4] VRBA, J. Application of microwave technics, ČVUT Praha, 2001 (in czech language)

### AUTHORS & AFFILIATION

<sup>1</sup> LUDMILA BRICHTOVÁ,

<sup>2</sup> RADIM ŠUBERT

<sup>1, 2</sup> TEXTILE FACULTY, TECHNICAL UNIVERSITY OF LIBEREC, DEPARTMENT OF TECHNOLOGY AND MANAGEMENT OF APPAREL PRODUCTION CZECH REPUBLIC



---

## ***EVALUATION OF INFLUENCE OF CRACKING GEAR-TOOTH ON CHANGES ITS STIFFNESS***

---

---

### ■ **Abstract:**

*In this paper the research results are shown which were to mark the influence of the cracking in the base of the tooth of wheel on the change of the wheel rigidity. In order to achieve this, a series of experiments was conducted with the use of models FEM and BEM. The correctness of the models was verified with the use of analytic method, whereas the final results were confirmed in a research experiment conducted on the endurance machine MTS. The achieved results enabled the conduction of research devoted to the possibility of use of simulation models of toothed gears to get the teaching data for artificial neural networks. The networks taught on the basis of such data would in consequence serve to be exploited on data coming from the real toothed gears.*

---

### ■ **Keywords:**

*gearbox, FEM, BEM, stiffness*

---

---

### ■ **INTRODUCTION**

*The meshing rigidity according to the ISO/DIS 6336 norm is defined as the ratio of the increase of the normal strength to the increase of the deformation existing in the buttress of pairs of teeth with the unitary width of the non-deviation gear. The deformation is determined in the perpendicular direction to the tooth profile in the front intersection.*

*The meshing rigidity is dependent on the toothed wheels geometry and the physical properties of the materials they are constructed of. The main factors influencing the values of meshing rigidity are [5]:*

- *the data concerning the meshing (number of teeth, the coefficient of the profile shift, the profile of the reference, etc.),*
- *the load value,*

- *roughness and waviness of the sides of tooth,*
- *elasticity module.*

*In the ISO/DIS 6336/1 norm a number of methods of meshing rigidity marking are given and they differ from each other mainly because the calculation precision of results. The most precise method of meshing rigidity marking is the A method, according to which in the conducted analysis all factors having influence on it should be taken into account. The methods in this group are numeric calculation methods, such as finite elements method FEM and boundary elements method BEM. In this paper both mentioned methods will serve as a tool to mark the meshing rigidity in both a proper and damaged gear. The use of the numeric methods in the tests of damages in toothed gears may be found in [1,3,4,6,10].*

In the literature one may find the simplified methods of meshing rigidity marking. Among them there is the suggested in [7] method of analytic marking of the meshing rigidity. That method, however, has serious limitations preventing the conduction of a complete experiment. This limitation is the possibility to mark the value of the meshing rigidity only for the undamaged teeth of the toothed gears. In this paper that method was used to verify the numeric models FEM and BEM.

Additionally on the endurance machine MTS the experimental verification of the results was conducted

■ **ANALYTIC METHOD OF MARKING**  
 ■ **THE MESHING STIFFNESS**

In paper [7] the following analytic way of marking the meshing stiffness was suggested:

- defining the material constants, the geometry of the tooth and the size of the load,
- marking the deflection of the tooth in the chosen points of the normal strength application to the profile,
- marking the deflection of the co-operating tooth in the previously assumed points of strength application (teeth co-operation),
- calculation of the flattening of the surface of both teeth in the successive points of contact,
- marking the total deformation of the pair of teeth,
- marking the meshing rigidity in separate defined co-operation points.

Marking of the changes in rigidity of a tooth in a pinion, the wheel and the meshing is conducted with the use of the dependence:

$$C_1 = \frac{F}{w_1} \quad (1)$$

$$C_2 = \frac{F}{w_2} \quad (2)$$

$$C_z = \frac{F}{\frac{F}{C_1} + \frac{F}{C_2}} \quad (3)$$

where:

$F$  – unitary load strength [N/mm],

$w_1$  – deflection of the tooth in pinion [ $\mu\text{m}$ ],

$w_2$  – deflection of the tooth of wheel [ $\mu\text{m}$ ],

$C_1$  – rigidity of the tooth of pinion [N/mm  $\mu\text{m}$ ],

$C_2$  – rigidity of the tooth of wheel [N/mm  $\mu\text{m}$ ],

$C_z$  – meshing rigidity [N/mm  $\mu\text{m}$ ].

Because this method does not enable to mark the tooth rigidity with a cracked base, it was used only to verify the numeric models of FEM and BEM.

In order to verify the FEM and BEM models, the results achieved with the use of them were compared with the results achieved with the use of Müller analytic method.

An example presented in [7] was used, with the following assumptions:

- number of teeth of pinion  $z_1 = 20$ ,
- number of teeth of a wheel  $z_2 = 35$ ,
- coefficient of the shaft of the pinion profile  $x_1 = 0,3$ ,
- współczynnik przesunięcia zarysu koła  $x_2 = 0,1$ ,
- thickness of the pinion  $s_{f1} = 2,033$  (this value corresponds with the value of the toothed gear module),
- wheel thickness  $s_{f2} = 2,077$  (this value corresponds with the value of the toothed gear module),
- angle of the profile  $\alpha = 20 [^\circ]$ ,
- tip clearance  $c_o = 0,2$  (this value corresponds with the value of the toothed gear module),
- the height of the tool head  $h_{ao} = 1,25$  (this value corresponds with the value of the toothed gear module),
- scale on the principal circle  $p_b = 0,282$  (this value corresponds with the value of the toothed gear module),
- number of contact  $\varepsilon_\alpha = 1,525$ ,
- unitary load  $Q = 4$  [MPa].

In the analysis of the meshing stiffness values marked with the use of numeric methods FEM and BEM and the Müller analytic method one may state their conformity in quality and quantity. The differences between the results achieved in Müller analytic method, FEM and BEM equalled 10 [%]. The differences in the achieved results may result from not taking into account in numeric calculations the contact

effects, which is the flattening of the teeth surfaces.

**MARKING OF THE MESHING STIFFNESS WITH THE USE OF FINITE ELEMENTS METHOD**

Marking of the meshing stiffness with the use of FEM method enables to take into account all factors appearing in contact of teeth in toothed gears. Such complete approach to the issue causes numeric difficulties and rather long numeric calculation time. That is why after conduction of a number of numeric experiments a simplified method of marking the meshing stiffness based on the assumptions of the analytic method shown in paper [7] was worked out.

After generating the profile of the pinion tooth and the wheel, the deformations are marked in points of strength application, and next the rigidity changes of a single tooth in a radius function separately for the pinion and for the wheel. Next, having in mind the course of rigidity changes of single teeth it is possible to mark the meshing rigidity of one pair of teeth in a randomly chosen point on the contact line. Knowing the meshing rigidity of one pair of teeth it is possible to mark the meshing rigidity in a multi-pair contact.

The geometry of the profile of a pinion tooth and the wheel was marked as a set of points coordinates on specially created software prepared by Transport Faculty of Silesian University of Technology. This software enables, in accordance with the assumed pinion or wheel parameters (module, number of teeth, correction, etc.) to mark the curve describing the evolvent part of the tooth profile and the shape of the tooth foot according to [9].

In the calculations three teeth of a wheel were used with fastened rim and normal strength to the profile loading the middle tooth. The unitary load strength was applied in successive points of the tooth profile. Those points were placed on the corresponding radii of the gear, being the equivalent of various points of teeth co-operation on the contact line.

In order to create the numeric model of the pinion and the wheel the program Cosmos/M. The net with the appropriately chosen density was constructed of elements type PLANE2D.

The created numeric model took into account the real shape geometry of a tooth and the

deformation of the toothed wheel rim. In the conducted calculations, during marking the meshing rigidity, the flattening of the surface of both teeth in successive points of contact caused by the touch of those surfaces was not taken into consideration.

In order to mark the influence of the crack in a tooth base on the meshing rigidity such wheels were used with parameters corresponding to the assumed during the simulation research with the use of dynamic model of a gear and the tests on the rotating power post FZG [2].

The crack in the foot of the tooth was modelled as an undercut with parameters presented in fig. 1.

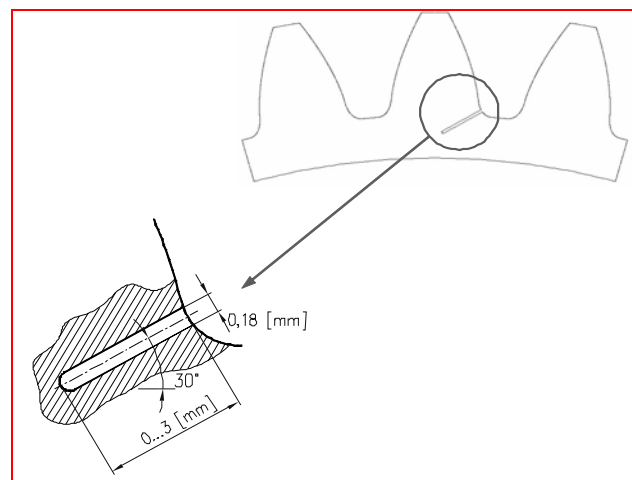

Fig. 1 Way of modelling the crack in the tooth foot.

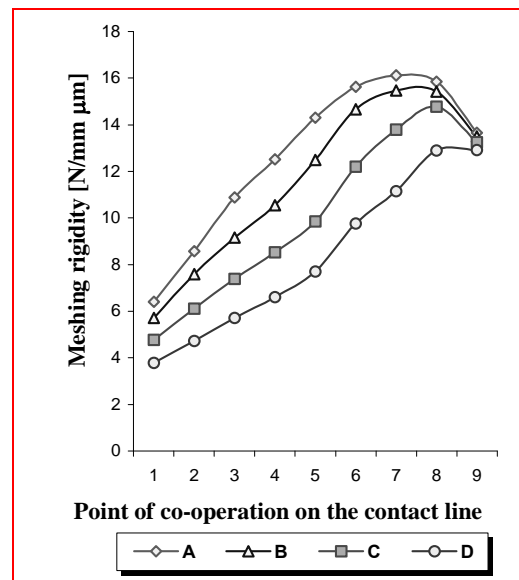

Fig. 2 Meshing rigidity marked with the use of FEM method, with the depth of the undercut: A – 0 [mm], B – 1 [mm], C – 2 [mm], D – 3 [mm].

The rigidity of the meshing marked with the use of FEM method are shown in fig. 2.

The position of the undercut was chosen in the point where the biggest concentration of the stress appeared in the foot of tooth on its stretched side [1,6,8,10]. The width and the depth of the gap were in accordance with the one assumed during tests on the real object of the working gear on FZG stand [2].

The tests were conducted for the correct gear and the gear with a defect in the form of a crack in the foot of wheel tooth.

The conducted analyses confirmed the correctness of the assumption in paper [2] about the decrease of meshing rigidity in case of appearing crack of the tooth base.

**MARKING OF THE MESHING RIGIDITY WITH THE USE OF BOUNDARY ELEMENTS METHOD**

In order to mark the meshing rigidity with the use of BEM method, special software was used, created for this purpose on the Faculty of Transport of Silesian University of Technology. This software enables to generate any profile of the teeth of a wheel and the calculation of the rigidity for wheels without damages, as well as with appearing damage in the form of a crack in the tooth base.

The assumptions of the tests were the same as the ones for FEM method.

The software, which was used, enables the refinement of the points of the tooth profile in places of biggest stresses concentration. This application enables the analysis of the flat state of the deformation, making it possible to take into the concentration directly the points describing the profile of the tooth as kinematic pairs of the boundary elements. In the tests the elements with three kinematic pairs and square functions of shape were used. The support method and the way of force application were in accordance with the ones assumed in meshing rigidity tests with the use of FEM method.

The conducted experiment was repeated for an undamaged wheel and for a wheel with an undercut in the foot of the tooth. The undercut was done on the depth of 1, 2 and 3 [mm], which was in accordance with the tests on a real object of a working gear on a rotating power post [2].

The results for meshing rigidity, achieved after BEM analysis, are presented in fig. 3.

The assumptions presented in paper [2] concerning the decrease of the meshing rigidity in case of the crack appearing at the base of the tooth were confirmed by the achieved results.

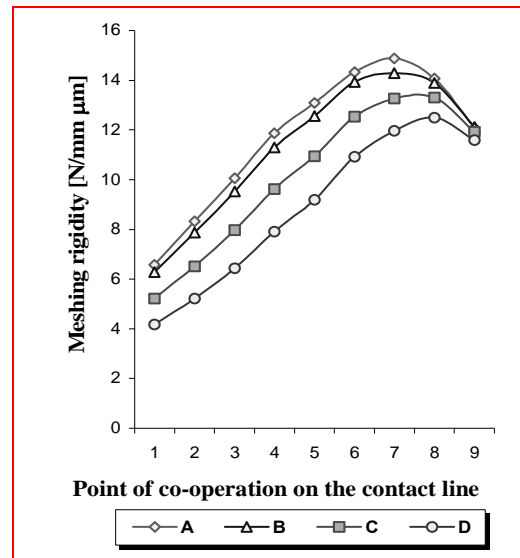

Fig. 3 Meshing rigidity marked with the use of BEM method, with the depth of the undercut: A – 0 [mm], B – 1 [mm], C – 2 [mm], D – 3 [mm].

**EXPERIMENTAL VERIFICATION OF THE RESULTS**

The aim of the tests was the experimental verification of the designed numeric model of a toothed wheel.

The machining station tests were conducted on a resistance machine MTS-810 with a power range up to 50 [kN] (fig. 4).

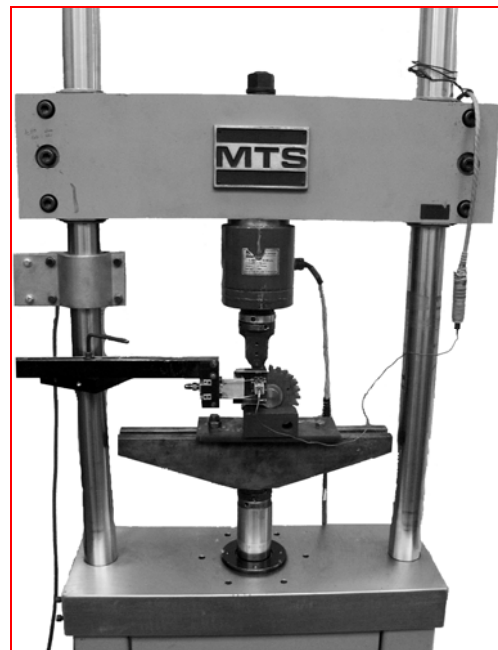

Fig. 4 The MTS-810 machine.

The use of the MTS machine in tests enables the conduction of the thermo-mechanical endurance tests.

The conducted tests were performed with steering of power ranging from 0 to 7.5 [kN]. The power range was chosen in such a way, in order not to exceed the elastic deformation. The load was applied on the wheel tooth tip.

In the experiments the deflection in the power application point in the direction of its influence was registered with the use of extensometers joined with the registration device.

The tests were conducted for an undamaged wheel and for a wheel with a modelled undercut in the tooth foot at the depth of 1, 2 and 3 [mm]. The parameters of the tested wheel were in accordance with the used in dynamic model tests of a toothed gear and the conducted test on rotating power post FZG [2].

The achieved results of the experiment were compared with the results achieved during tests with the use of FEM and BEM and put together in fig. 5.

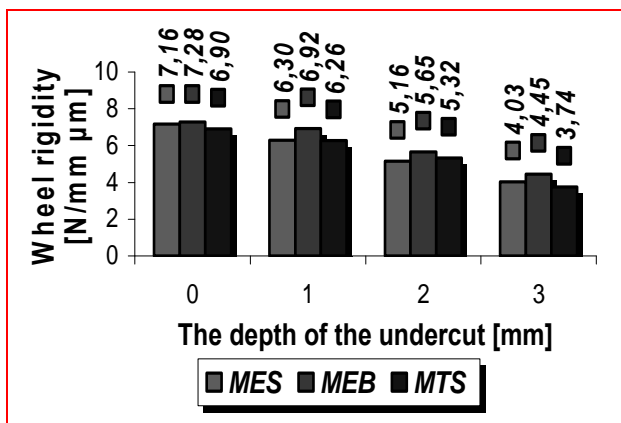

Fig. 5 Rigidity of a wheel tooth marked on its tip

The conducted tests on an endurance machine MTS confirmed the correctness of the numeric experiments using FEM and BEM.

The appearing differences may result from the applied methodology, different in case of each experiment.

## CONCLUSION

On the basis of the achieved results, in paper [2] the following influence of the crack in the tooth foot on the change of meshing rigidity was assumed:

- 0 [mm]: 0...9 % change of meshing rigidity,
- 1 [mm] 10...19 % change of meshing rigidity,
- 3 [mm] 30...40 % change of meshing rigidity.

These assumptions enabled in the next part of the tests [2] to check the correctness of neural classifiers work, which were taught with the use of standards achieved from a dynamic model of a toothed gear working in a power transmission system. The testing process, however, was conducted using data achieved from a real gear [2].

## REFERENCES

- [1.] CIAVARELLA M., DEMELIO G.: Numerical methods for the optimization of specific sliding, stress concentration and fatigue life gears. *International Journal of Fatigue* 21 (1999), str. 465-474.
- [2.] CZECH P.: Wykrywanie uszkodzeń przekładni zębatych za pomocą metod sztucznej inteligencji. Rozprawa doktorska. Katowice 2006.
- [3.] DING Y., JONES R., KUHNELL B.: Numerical analysis of subsurface crack failure beneath the pitch line of a gear tooth during engagement. *Wear* 185 (1995), str. 141-149.
- [4.] HOWARD I., JIA S., WANG J.: The dynamic modeling of a spur gear in mesh including friction and crack. *Mechanical Systems and Signal Processing* (2001) 15(5), str. 831-853.
- [5.] JAŚKIEWICZ Z., WĄSIEWSKI A.: Przekładnie walcowe. Wydawnictwa Komunikacji i Łączności. Warszawa 1992.
- [6.] KRAMBERGER J., SRAML M., POTRC I., FLASKER J.: Numerical calculation of bending fatigue life of thin-rim spur gears. *Engineering Fracture Mechanics* 71 (2004), str. 647-656.
- [7.] MÜLLER L.: Przekładnie zębate. Dynamika. Wydawnictwa Naukowo-Techniczne. Warszawa 1986.
- [8.] MÜLLER L.: Przekładnie zębate. Obliczenia wytrzymałościowe. Wydawnictwa Naukowo-Techniczne. Warszawa 1972.
- [9.] MÜLLER L.: Przekładnie zębate. Projektowanie. Wydawnictwa Naukowo-Techniczne. Warszawa 1996.

[10.] PEHAN ST., HELLEN T. K., FLASKER J., GLODEZ S.: Numerical methods for determining stress intensity factors vs crack depth in gear tooth roots. *Engineering Fracture Mechanics* Vol. 19 No. 10, 1997, str. 677-685

---

■ **AUTHORS & AFFILIATION**

---

<sup>1</sup> PIOTR CZECH,

<sup>2</sup> PIOTR FOLEGA,

<sup>3</sup> GRZEGORZ WOJNAR

<sup>1. 2. 3</sup> FACULTY OF TRANSPORT, SILESIA UNIVERSITY OF TECHNOLOGY, GLIWICE, POLAND



## DETERMINATION OF SEWN SEAM IMPACT STRENGTH

### ■ Abstract:

This article defines strength as the fundamental function property of the seam which characterizes possibilities of using of technical ready-made products. Strength is the force which the seam resists. There are presented the measuring methods of seam strength in dependence on the method of strain. According to the method of strain the seams have to resist the forces which act quasi statically or at impact. It is necessary to differentiate and define impact strength and to know how to measure it.

### ■ Keywords:

strength, impact, technical ready-made product, force, strain

### ■ INTRODUCTION

The study of strength of the sewn seam is necessary for production technical ready-made products. The sewn seams are used in new zones of an application and the diversity of application become greater. They are evolved new textile fabric with new using properties and new manufacturing technology.

The production of the technical ready-made products means processing of the flat textiles with the seams to the three-dimensional products, which serve special purposes and have to resist special and often very severe conditions of application. In some applications of technical ready-made products (parachutes, airbags, safety belts ...) there are the activities at which the impact forces rise and act on the fabric and its seams. In some cases the human life can be in danger by the malfunction of these products. That's why a great stress is put on the seam strength as its fundamental function property. Literature about these problems isn't known. Properties of the seams was analysed in [1, 2] and problems about technical ready-made products production are solved for example in [3].

### ■ THEORETICAL DETERMINATION OF SEWN SEAM STRENGTH

#### ■ Strength of the sewn seam

Strength of the sewn seam can be less than strength of a textile fabric. It is the property which represents behaviour of connected fabric in conditions of mechanical action. It characterizes seam from the view of the ability to resist impacts of external forces without any defect.

Transversal seam strength characterizes resistance of the seam to external strain which impacts perpendicularly to an orientation of the seam. It represents the force which is needed for destruction of the seam by nonreversible change (destruction of the sewn thread, destruction of the connecting material, moving of the tread on the seam).

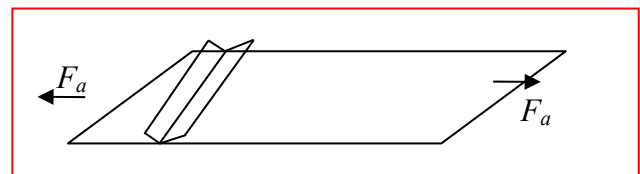

Figure 1: The graphic presentation of seam mechanical tensile strain

Theoretical transversal seam strength is maximal value which is able to reach. It is defined as a linear function of thread strength in a loop and quantity of tied points belonging to the length of the seam.. Real transversal seam strength ( $F_s$ ) is less than theoretical because the strength of the sewing thread decreases during the formation of stitch. It is characterized by the coefficient of the damage of the thread, which is the rest of the strength of the thread after the sewing.

■ **The prediction function**

The prediction function for the theoretical calculation of the real seam strength has this form:

$$F_s = 2 \cdot 10^{-4} \cdot d_s \cdot l_s \cdot \alpha \cdot F_t \cdot F_{rtl} \cdot F_{rts} \quad (1)$$

where:

- $F_s$  ...real strength of the seam [N]
- $F_t$  ...strength of the thread [N]
- $F_{rtl}$  ...relative thread strength in the loop [%]
- $F_{rts}$  ...relative strength of the thread after sewing [%]
- $d_s$  ... density of the stitch [ $cm^{-1}$ ]
- $l_s$  ...width of the sample (length of the seam) [mm]
- $\alpha$  ... coefficient of the seam

■ **The influential factor**

There are three groups of the influential factors:

- ✚ the material influential factors (connecting material, threads)
- ✚ the parameters of connecting (type of the seam, type of the stitch, width of the seam, density of the stitch, direction of the sewing)
- ✚ the method of strain (quasi static, impact)

Measured values of strength are dependent on the speed of material deformation.

When the speed of deformation is higher all mechanisms of plastic deformation aren't able to open wide, so the material is broken at higher value of tension, but at lower value of elongation. It means material presents as fragile [4].

The values of strength measured at static tests and at impact tests will be different. This difference in behaviour of material represents the value of impact coefficient  $C_I$

$$C_I = \frac{A_{defl}}{A_{defS}} \quad (2)$$

where  $A_{defl}$  ( $A_{defS}$ ) is average value of deformation work by impact strain (by static strain).

Impact strength can be calculated when this forces values are considered as static and multiplied by impact coefficient which can be determined by test..

■ **EXPERIMENTAL MEASURING OF SEWN SEAM STRENGTH**

■ **Methods for measuring of the strength**

Mechanical characteristics present quantitative level of effect of mechanical strain. They are determined by mechanical tests.

**Mechanical tests – static test**

- the test sample is strained by external force which is increased slow by lower speed then the speed of propagation of plastic deformations in normal conditions till damage of the sample
- the value of force for deformation or for destruction of the sample is measured at this test

**Mechanical tests – impact test**

- the test sample is strained by external force which is acting quickly by impact of other solid with defined speed of fall (Charpy pendulum hummer)
- the value of using work for deformation or for destruction of the sample is measured at this test

**Impact strength**

The measuring of impact strength of textile fabrics and its seams is a difficulty solvable technical problem. The pendulum hammer is used at impact test. It is constructed so that the material will be broken when passes zero position.

The apparatus for measuring impact strength on the laboratory textile sample was projected and constructed on Technical University of Liberec, Department of Technology and Management of Apparel production (figure 1).

**Description of apparatus**

The apparatus is composed of a frame (1), swing hummer (2), fixative yaws (3, 4), gauging device (5, 6), brake (7). Basic measuring element is angular scale (5), where pointer (6) enabling read the angle of swing is placed. The fixative yaws are placed in direction acting force. The front edges are perpendicular to direction acting force. The fixative surfaces are on the same plane – on plane of strain textile (8), they are knurled for reliable holding of the sample without slippage but they can't cut through or



damage the sample. The left yaw is turning – it makes possible swing, the right yaw is fixed.

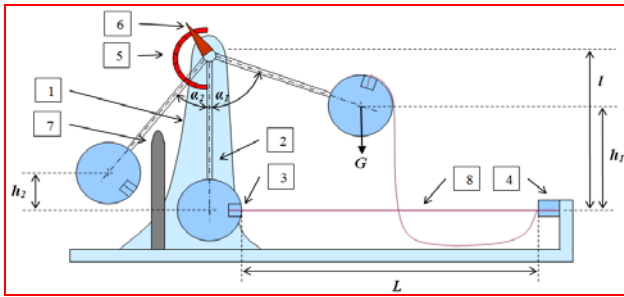

Figure 1: The apparatus for measuring the impact strength of the textile fabric and seams

The apparatus is hand-controlled. It enables positioning of swing hammer to three position (the swing angle is 45°, 90°, 135°) for another samples. The fixed length which makes possible swing is defined as 1, 2 m..

**Principle of the method**

The sample is fixed into the jaws down (basic) position. The turning jaw gets potential energy  $E_{p1}$  when swings to height to  $h_1$  (or by angle  $\alpha_1$ ). The geometry position of the sample just before destruction is determined for impact strength. This method supposes strain of a sample in centre of impact of the hummer. When we drop the jaw, we can imagine that after the thrust of a sample the impulse of force will be acting at impact, perpendicularly to the seam, in the direction of sample length.

The sample will be destructed in the lowest position. The pendulum will swing to opposite position to height  $h_2$  (or by angle  $\alpha_2$  which is registered on a scale). This position corresponds to the residual energy  $E_{p2}$ .

Absorbed deformation energy  $E_{def}$  is given by difference potential energies:

$$E_{def} = E_{p1} - E_{p2} = m g (h_1 - h_2) \quad (3)$$

Decrease of energy is direct proportional to the expended deformation work. The calculation model was get from the difference between initial and final state and form the well-known goniometric formulas:

$$h_1 = l (1 - \cos \alpha_1) \quad (4)$$

$$h_2 = l (1 - \cos \alpha_2) \quad (5)$$

There is the calculation model of deformation work  $A_{def}$ :

$$A_{def} = m g l (\cos \alpha_2 - \cos \alpha_1) \quad (6)$$

The basic for calculation of deformation work is the initial value of the setting angle and the final

value of the swing angle, when the weight of the hummer ( $m = 21,1 \text{ kg}$ ) and the length of the hummer ( $l = 802,5 \text{ mm}$ ) are known. The length of the hummer is the distance between the centre of gravity of the hummer and the axis of rotation.

**Measuring procedure:**

Examinational sample is fixed one end to the jaw of the swing hammer in the basic position and the second end to the stationary gripping jaw (fig. 1). Sample must be fixed so, that it is tight – to this purpose serves initial tension through small weight (50 g).

Pendulum is swung in the angle ( $\alpha_1$ ) and is locked (fig. 1 position 1). After unlocking follows free-fall, position energy is changed to kinetic energy, which is maximal in the down position. Impact force acts to the sample. Textile is broken and pendulum is swung to the opposite position (fig. 1 position 2). Angle value ( $\alpha_2$ ) is read from the scale, angle is equal to the rest energy.

**Sample preparation:**

Samples are prepared according to the norm EN ISO 13935-2 with following differences:

Laboratory sample (fig. 2) is made from textile material size 1200mm x 1400mm, which is folded so, that the edge of the fold is parallel with the shorter side of the sample. In defined distance from the fold (usually 20mm) is made up demanded seam. Sample is cut in the fold before sewing together (when it is the lapped seam material is lapped). Seams are sewn in direction of the weft or according to the demands. Sewing machine must be rightly set up, sewing must be straight and every stitch must be perfectly bound from the beginning to the end of the sewing. Both sides of the laboratory sample are cut of 100mm waste.

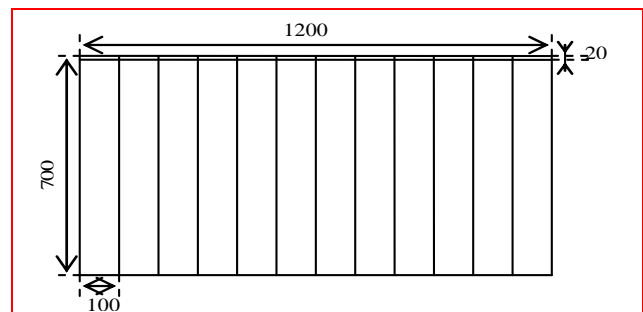

Figure 2: Laboratory sample for impact test

Set about ten examinational samples 100 mm x 1360 mm is cut and modified on defined shape (fig. 3) from the laboratory sample with the seam. Every examinational sample is four times

notched until 33 mm in distance 20 mm from the seam. The rest of the material is cut off so, that the real width of the sample will be 34 mm. Length of the examinational sample is given according to the seam (usually 1360 mm).

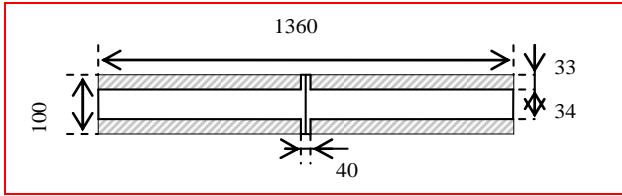

Figure 3: Examinational sample for impact test

## EXPERIMENTAL RESULTS AND EVALUATION

### Measuring values

The output values from impact test are initial angle of fall ( $\alpha_i$ ) and final angle of swing ( $\alpha_f$ ). The output values from static test are values of strength ( $F$ ), elongation of sample ( $\Delta l$ ) and graphic record of course of test.

### Treatment of measuring values

Absorbed deformation work at impact strain  $A_{defl}$  was calculated according to model (6). Absorbed deformation work at static strain  $A_{defS}$  was calculated from graphic record of course of test:

$$A_{defS} = \int_0^{\Delta l} F \cdot dl \quad (7)$$

The integral present area of figure which is limited by I-axis and by graph of function  $F(l)$  given by tensile curve. The trajectory is given by elongation of sample.

### Evaluation of impact coefficient

The measuring value absorbed deformation work at impact strain  $A_{defl}$  was compared with value absorbed deformation work at static strain  $A_{defS}$ . The results of measuring (table 1) confirm hypothesis that absorbed deformation work at impact strain will be always higher than absorbed deformation work at static strain and the value of impact coefficient will be always higher than one. It means that deformation resistance is lower at impact strain.

Table 1: The results of strength valuation

seam type	stitch type	$A_{defS}$ [J]	$A_{defl}$ [J]	$C_1$
1.01.01	1 x 301	1,172	7,877	6,72
2.01.01	1 x 301	1,138	8,070	7,09
2.01.03	2 x 301	2,190	8,201	3,74
2.01.04	3 x 301	3,710	11,007	2,96
2.02.01	1 x 301	0,857	8,632	10,07
2.04.01	1 x 301	0,886	8,632	9,74

It is needed criticize dependence of deformation work not only on impact force (strength) but also on trajectory (elongation of sample).

## CONCLUSION

The problems of prediction of seam strength are evolved theoretically. The universal model of function dependence for calculation of the real perpendicular strength of seam was elaborated. It has important application in projecting of seam. The difficulty of mechanical impacting on components of the seam causes that this model isn't enough exact for all of the seams. Many of different influences impact into the strength and it is needed to analyze them.

The using properties of technical ready-made products are given not only by using textiles but also by technological ready-made procession. The knowledge of strength characteristic not only at quasi static strain but also at impact strain is necessary condition for successful projecting to the seams.

The test of the impact strength of textiles and seams determined its behaviour at sudden grown of acting force. This test evaluated the impact strength by objective method and on the standardizing samples. We can reproduce the test with the same condition.

This test makes possible to evaluate the other properties of textiles and seam and to guarantee quality and rightness of using.

## REFERENCES

- [1] Nahtquerfestigkeiten, Die Naht – Nähetechnische Informationen von Gütermann, 1986, Nr. 86, S. 6
- [2] DOSEDĚLOVÁ, I.: The Strength of the Sewn Seam – the Prediction Function, the Influential Factors, In Structure and Structural Mechanics of Textile Fabric, Technical University of Liberec, 2005, ISBN 80-7372-002-7, 335-340
- [3] KUNZ, O.: Konfekcionování technických textilií, sborník z odborného semináře Problematika konfekcionování technických textilií, KKV Prostějov 2001
- [1] KOŠKOVÁ, B., KOŠEK, M.: Struktura a vlastnosti vláken, VŠST Liberec, 1991

## AUTHORS & AFFILIATION

<sup>1</sup> IVANA DOSEDĚLOVÁ

<sup>1</sup> DEPARTMENT OF TECHNOLOGY AND MANAGEMENT OF APPAREL PRODUCTION, TECHNICAL UNIVERSITY OF LIBEREC

---

## **QUANTIFICATION AND ANALYSIS OF TECHNOLOGICAL PARAMETERS RELEVANCE IN CONTINUITY WITH CUT AREA QUALITY**

---

---

### ■ **Abstract:**

*Manufacturing system production quality with technology AWJ is influenced by various factors. Important influence has on it also technological parameters set of manufacturing systems from those every in other range and to it corresponding importance influences quality and working cost in manufacturing systems.*

*The article busies with manufacturing systems with technology AWJ and technological parameters influence on cut area quality at cutting steels HARDOX. The article presents the results of experimental research technological parameters influence. In the article the principles and recommends for firms that perform working manufacturing systems with technology AWJ are also formulated.*

---

### ■ **Keywords:**

*technology AWJ, technological parameters influence, cut area quality*

---

---

### ■ **INTRODUCTION**

*Manufacturing system production quality with technology AWJ is influenced by various factors. Important influence has on it also technological parameters set of manufacturing systems from those every in other range and to it corresponding importance influences quality and working cost in manufacturing systems. The article presents experimental research results of manufacturing systems technological parameters influence on parameters quality of cut area aimed at activity importance stating choice three technological parameters on cut area quality at cutting steels HARDOX with technology AWJ. On foundation of experiments*

*evaluation mathematical models are created and on their basis activity importance of choice three technological parameters on parameters of cut area quality is stated a graphical represented. Stating technologic parameters activity importance enables at working states diagnostification to concentrate on these parameters that decisively influence cut area quality and to judge their activity also in wider context in bond on working cost and economical effectiveness of manufacturing systems with technology WJ working. In the article principles and recommends for firms that perform working manufacturing systems with technology AWJ are also formulated.*

**TECHNOLOGICAL PARAMETERS SIGNIFICANCE AND RELEVANCE IN CONTINUITY WITH CUT AREA QUALITY**

From concrete mathematical model it is possible to state with help of the programme STATISTIKA to state and graphically to represent technological parameters influence significance value in percent on competent cut area quality parameter.

Technological parameters significance is stated in the form of significance diagram for concrete mathematical model (numerical functional dependence of technological parameters influence on parameters of cut area quality) with utilization of the programme STATISTIKA in entering into relations with:

- parameter of cut area quality
  - thickness of cut material
- At solution was stated and graphically represented significance set for:
- 5 parameters of cut area quality (roughness of surface Ra, Rz, Ra4, Ry4 measured in distance 4 mm from cut area top edge, deviation angle of water jet Ø)
  - 4 cut material thicknesses 6, 10, 15, 40 mm

**EXPERIMENTS**

Entirely 45 samples (9 samples from every sheet thickness 6, 10, 15, 40 mm and to it 9 samples from 6 mm thick sheet cut with increased values of cut head speed by 50 percent against speed „v”). Number of all cut areas (at 3 areas on every sample) presented the value 135. Figure 13 presents lucidly set of all cut samples.



Fig. 1 Set of all 45 cut researched samples

Table 1 contains specimen from data measured on samples

Thickness of sample h						40 mm	
Identification of Sample		Technological Parameters				Qualitative Parameters	
Number of sample	Number of area sample	$m_A$ [g/min]	P [MPa]	$v$ [mm/min]	t [s]	Ra	Rz
	1	170	300	10	240	3,65	20,84
I		170	300	60	40	4,09	21,90
	3	170	300	80	30	6,95	24,96
	4	170	340	40	60	2,90	19,79
II		170	340	60	40	3,92	21,00
	6	170	340	80	30	5,87	23,64
	7	170	380	40	60	2,83	19,11
	8	170	380	60	40	3,66	20,81
III		170	380	80	30	4,10	22,90
	10	220	300	40	60	2,75	18,67
IV		220	300	60	40	3,46	20,56
	12	220	300	80	30	4,07	21,10
	13	220	340	40	60	2,71	17,14

**EXPERIMENTS EVALUATION AND DISCUSSION**

Figure 2 presents specimen of concrete diagram from set of diagrams of three technologic parameters significance v, p,  $m_A$  and absolute member. The absolute member shows accuracy of model functional dependence. On foundation of it significance diagram was created but mainly total activity of the others little significant technological parameters.

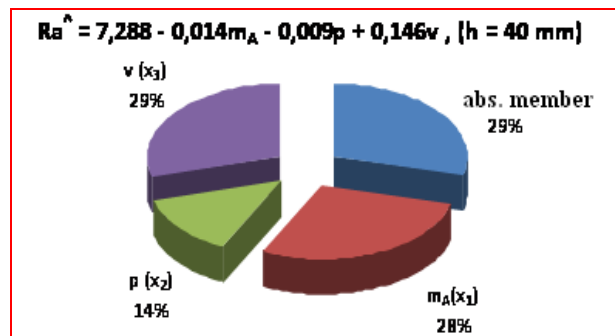

Fig. 2 Significance diagram of mathematical model technological parameters for cut area quality parameter Ra (h=15mm)

In table 2 significances of three technological parameters on fire parameters on five parameters of cut area - area quality for thickness of cut material 40 mm are stated. The data (v, p,  $m_A$ , absolute members) stated in table 2 for Ra are taken over from significance diagram for Ra on fig. 2. Data for further parameters of cut area quality stated in table 2 (Rz, Ra4, Rz4, Ø) are

taken over into it from analogous significance diagrams (for Rz, Ra4, Rz4, Ø).

Table 2 Technological factors significance,  $h = 4 \text{ mm}$

Technological parameter + absolute member	Significance of technological parameters %				
	Parameter of cut area quality				
	Ra	Rz	Ra4	Rz4	Ø
$v$	29	24	39	38	28
$p$	14	10	7	1	15
$m_A$	28	26	22	19	28
absolute member	29	43	32	42	29

### NEW KNOWLEDGE AND RECOMMENDS

Shown knowledge are applied for cutting of abrasion resisting steel HARDOX 500, thickness 40 with technology AWJ.

- from judged three technological parameters on 5 choice parameters of cut area quality parameter  $v$  has the greatest significance, parameter  $m_A$  has something smaller significance and parameter  $p$  in average less than half significance
- it is possible to improve cut area quality mainly roughness of cut area surface in deep 4 mm from cut material surface (Ra4, Ry4) with change of parameter  $v$
- it is possible most to influence parameter of cut area roughness Rz with change of parameter  $m_A$
- it is possible with change of parameter  $p$  to improve cut area quality mainly Ø, Ra much less it is possible to influence parameter Ra4 and on minimum measure only parameter Rz4
- total influence of further technological parameters shows most at parameters Rz, Rz4 minimum and nearby equal influence at parameters Ra, Ø.

Analogously it is possible to formulate knowledge and recommends also for further researched thicknesses of cut material and on their foundation also knowledge influencing from mutual comparing conclusions for single cut thicknesses.

### UTILIZATION REGIONS AND MAIN CONTRIBUTIONS

Knowledge are utilizable in scientific area (original mathematical models, activity significance of three choice technological

parameters), but also in firms working manufacturing systems with technology AWJ and in pedagogical process.

### CONCLUSION

The article busies with actual technology AWJ for firms working manufacturing systems and acute problematic of activity significance choice technological parameters on cut area at cutting abrasion resisting steels HARDOX with technology AWJ. On the basis of evaluated experiments conclusions and recommends are elaborated and concrete examples are stated. The solution creates one from foundations for modeling and simulation of technological parameters on cut area quality influence with establishing systems working with technology AWJ. It is possible to utilize methodic of exercised solution in article in the form of analogy also for further especially relative jet technologies. The article presents partial knowledge of dissertation work [3] solution and partial results of the grant work VEGA solution.

### ACKNOWLEDGMENT

The contribution presents the part results of the task VEGA 1/0544/08 solution.

### REFERENCES

- [1.] FABIAN, S., STRAKA, L.: *Prevádzka výrobných systémov. Edícia vedeckej a odbornej literatúry FVT TU v Košiciach so sídlom v Prešove, Prešov 2008. ISBN 978 – 80 – 8073– 989 – 8*
- [2.] FABIAN, S.: *Presentation of the developed laboratory vibrodiagnostic of machines and production systems operational states. Scientific papers, p.p. 30-38, Tribun EU Brno, 2008, ISBN 978-80-7399-634-5*
- [3.] SERVÁTKA, M.: *Modelovanie, simulácia a optimalizácia technologických parametrov v návaznosti na požadovanú kvalitu produktov vo výrobných technológiách s vodným lúčom. Kandidátska dizertačná práca. Prešov 2009, FVT TU Košice so sídlom v Prešove*
- [4.] SERVÁTKA, M., BIČEJOVÁ, L., FABIAN, S.: *Súbor technických možností znižovania vibrácií*

*strojov a výrobných systémov v prevádzke.  
In.: Management of manufacturing systems,  
Prešov 2008, s. 121-123. ISBN 978-80-553-  
0068-9*

- [5.] *BIČEJOVÁ, L., FABIAN, S.: Techniky a metódy  
vyhodnocovania signálu generovaného  
vibračným procesom pri prevádzke  
výrobných systémov. In.: Výrobné  
inžinierstvo č. 4/2008, s. 56-58. ISSN 1335-  
7972*

---

■ **AUTHORS & AFFILIATION**

---

<sup>1.</sup> *STANISLAV FABIAN*

<sup>1.</sup> *DEPARTMENT OF MANUFACTURING PROCESSES  
OPERATION, TECHNICAL UNIVERSITY OF KOŠICE  
WITH A SEAT IN PREŠOV, SLOVAKIA*



## THE PLOUGHING EFFECT AT DRILLING OF THEIR INFLUENCE ON THE PRODUCTION OF HOLES

### ■ Abstract:

Automated production has characteristic features: a reduction of production costs, stimulation of the development of cutting tools, and changes in the construction of machine tools, all of which work against the creation of optimal technological methods, which thrusts the technological process of cutting into a more important position. These trends confirm that the cutting process remains one of the basic manufacturing technologies. This article presents the results of experiments that concerned the verification of tool wear and special "Ploughing effect" on the cutting tool of workpieces of difference types of austenitic stainless steel. The paper present of real experimental results. The authors would like to thank in words the KEGA grant agency at the Ministry of Education SR for supporting research work and co-financing the projects: Grant work KEGA #3/7166/2009

### ■ Keywords:

tool wear, cutting zone, cutting tool, drilling

### ■ INTRODUCTION

The cutting proces is interaction between cutting tool and workpiece. Every material has a internal energy, which in cutting proces change. This is energy has the main influence on the results by drilling. On the start is defined internal energy  $E_t$  of cutting tool, the next is defined internal energy of workpiece  $E_w$ . The themodynamical phenomenas is orientated on the problems of research of tensions on the tool figure 1 and definition the motion energy between interaction two materials influence. The result is equations

$$E_w + E_t \Rightarrow \text{surface conditions(quality, precision,tension)} \quad (1)$$

$$E_w = \text{function(microstructure,chemicalcondition)} \quad (2)$$

$$E_t = \text{function(microstructure,chemicakonditionhardness)} \quad (3)$$

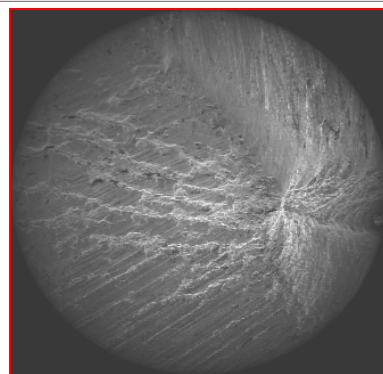

Fig.1 Tension place on the cutting tool - clearance area, mag.100x

### ■ DEFORMATION IN CUTTING ZONE

Stainless steel they have individual requirements, but require reach at it, that can a few brand stainless steel, between that requirements about metal cutting differ. Applied

modern special implements enable reduce generality problems, connect with machining present band material, alternatively these mess enable absolutely cast out about their true app. Austenitic stainless steel are one from the main tip of stainless steels, that applied because machining fabrication component. Be due broad appliance and machined chiefly turning and drilling. Bases requirements about cutting tool because metal cutting of stainless steel in compare with another alloy steel are, [2], [3] [4], [8]:

- advanced addiction at built up edge (BUE)
- drift at hardening of material.

These requirements we can chiefly eliminate true alternative inserts, videlicet band (ISO-M), that recommends generality world machinist of cutting tools. Action machining of stainless steel is dearly many a time accompanying birth BUE on the cutting edge, that make bucking tool life (currency) of cutting tool, affects brand of machined surfaces, give out at alteration dynamic characteristic of cutting process (cutting forces, cutting resistance,...), come-down action chip formation, as well as affect about assurance machining. In machining operations, mechanical work is converted to heat through the plastic deformation involved in chip formation and through friction between the tool and the workpiece, [1], [5] [6], [7]:

**EXPERIMENTAL PART**

Drilling tests were carried out using a vertical machining centre equipped with 10 000 rpm, 16 kW spindle. The tests used and HW-M20 drills with a diameter of Ø 10 mm, at a cutting speed of 40 m/min and feed of 0,1 mm/rev were used without coolant. All experiments was realized in practice by production product from X6Cr16Ni9Mn steel. In the tests used HW-M20 by conditions - cutting speed preliminary 25 m/min, presented in figure 2. Characteristical tool wear for different cutting conditions show is table 1.

About machining of stainless steel needed adhere following commendation, that are results experimental measured at laboratory and applied clause, [9], [10], [11], [12], [13], [14]:

- needed act machining material attest
- apply inserts ISO-M
- secure consistence system machine-tool-workpiece-fixture

- technological discipline maint manufactural engine
- cutting tool exchange already about knock-down number of cutting edge
- cutting tools cast a voice by your leave capacity conjunction because surety adequate consistence and efficacious conscription warm of cutting tool

Tab.1 Tool wear at the cutting part

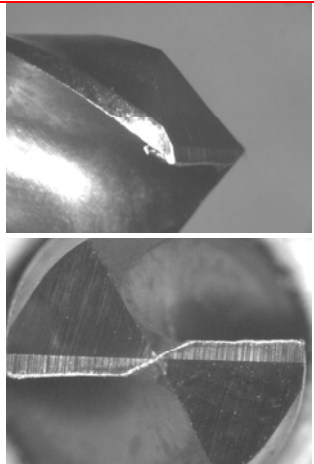
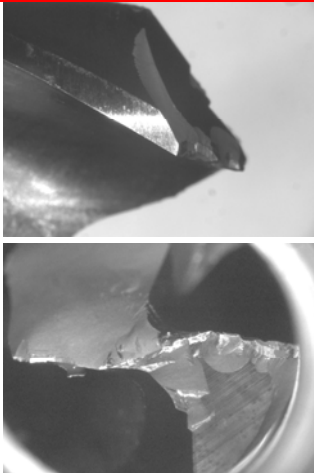
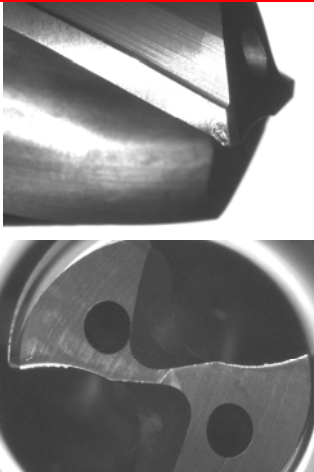
Type of the cutting material	Tool wear at the cutting part
HSS	
HW-M20	
HW-JET	



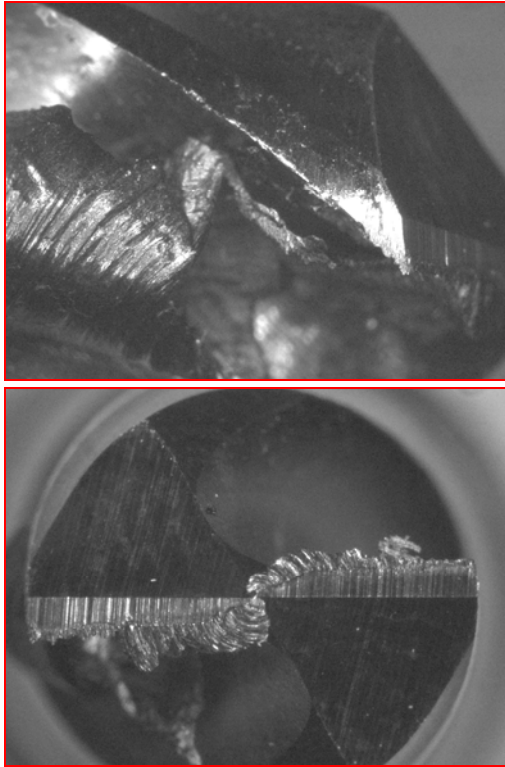

Fig.2 The drill used in cutting tests. The formation of built-up edge (BUE) is present, HSS

In the course of material selection, the cutting process generally can arise from the traits which the work piece material and the conditions of the cutting process. This character is material machinability. According to Cook material machinability is a quality of the material that expresses its capacity to process the work piece from the point of view of its functional qualities. Creation and formation of chips and tool wear of the cutting edge of the instrument influence the capacity of work piece processing. According to Tipnis material machinability is expressed as a quality of the material, which is defined by the state of the cut surface, the creation and shaping of chips, the effect of cutting forces and the durability of the cutting edge. According to Loladze, material machinability is a quality of the object material, which expresses its qualitative state by yielding to the effect of the cutting wedge. According to Victor, material machinability is a concept expressed by impermanence, change, and one with many possible meanings. According to the authors of this article, work piece material machinability is a quality of the work piece material that is defined in each individual case by the precise method of the cutting process, and the conditions of the technological system of instrument-object-setup. According to Mikovec

a collection of hard-to-machine materials comprises: construction steel selected for high strength and firmness, tempered austenitic manganitic stainless steel, nonmagnetic nickel-manganese and chrome-manganese steels, stainless and high-alloyed chrome steels, austenitic stainless steels, refractory and heat-treated, hardened chrome-nickel steels, nickel and cobalt alloys, highly-smeltable metals and several further types of powder-metallurgy productions. Sintered carbide instruments are preferable in a cutting instrument, according to the author's recommendations. Mikovec recommends values for the dimensions of cutting instruments. In turning austenitic stainless steels, it is not recommended a negative facing angle be chosen, because it causes strain hardening along the cutting surface, and because it produces constant chips, so a cutting lathe can be used instead, with chip shapers. According to the author the choice of cutting conditions depends on the type, shape, size (thickness and firmness) of the cutting instrument, and the type, size (thickness), and capacity of the turning machine, and most of all of the material of the cutting portion of the instrument, the required life of the cutting wedge, and the material of the work piece. For austenitic stainless steels, which are characterized by strain hardening of the surface during the cut, it is recommended that the thickness of chip  $h_1$  be larger than 0.1 mm. The cutting zone is a summary term from the region during cutting To properly describe the cutting zone it is necessary to describe the regions and test parameters. Primary plastic deformation zone (primarily an examination of phenomena associated with the creation and formation of chips, with the effect of the components of cutting force-the state of strain deformation, the location of the angle of the shear level, chip compression, the temperature field, chip shape, chip formation and separation, the effect of the components of cutting force) Secondary plastic deformation zone (primarily an examination of phenomena associated with friction and cutting wedge wear, and also with the generation of heat and temperature-the location of the grain angle, the contact length of the cutting wedge and the face plate, friction stress and scab creation (BUE), friction, the generation of heat and temperature, the mechanism of tool wear). Tertiary plastic

deformation zone (primarily an examination of the phenomena associated with the shaping creation of the machined surface, its profile, morphology, qualities and inherited traits-contact of the machined surface and the worn side plate). Cutting surface, its properties and integrity. The gradually-deformed region of the cut layer.

## CONCLUSION

Tool wear monitoring is economically very important but technically a rather demanding task. In this paper an attempt has been made in order to reach further understanding of the dynamics that influence the drilling process and especially what happens when a drill is worn. A very simplified approach has been tested in the development of the cutting forces and modeling the influence of wear in these forces. Such factors as geometrical difference of the cutting lips, different kind of wear history of the lips, vibration at first natural frequency and excitation at harmonics of the speed of rotation have been taken into account in the development of the excitation force. The developed forces have been used for excitation of a simplified one degree of freedom model of the drill. The dynamic model has been used for producing vibration velocity signal as a function of drill wear and with this signal the most typical and widely used signal analysis techniques i.e. statistical time domain parameters and spectrum analysis have been tested.

## REFERENCES

- [1] AGAPIOU, J.S.-STEPHENSON, D.A.: *Metal cutting theory and practice*, CRC Press, 2006. 846 p.
- [2] JURKO, J.: *Vřtanie austenitických nehrdzavejúcich ocelí*. Prešov, D.A.H. Prešov, 2005, 101 pages
- [3] JURKO, J.: *Opotrebovanie rezných nástrojov*. Prešov, D.A.H. Prešov, 2005, 110 p.
- [4] JURKO, J.: *Plastická deformácia v procese rezania*. 1. vyd - Prešov : FVT TU, 2007, 132 p.
- [5] JURKO, J.-LUKOVICS, I.: *Vřtanie-Technologická metóda výroby dier*. 1. vyd., Zlín : UTB, 2007. 191 p.
- [6] LUKOVICS, I.: *Research of HSC*. In:COM-MAT-TECH, 2004, 12-th International Scientific Conference, 14.-15.10.2004 Trnava, p. 124

- [7] MÁDL,J.-TESNER,L.: *Tool Wear Monitoring in Machining*. Zborník z medzi-národného kongresu MATAR, Praha : ČVUT Praha, 1996, 169 p.
- [8] MRKVICA, I.-MORAVEC, V.: *Úpravy břitů a povrchů řezných nástrojů*. MM Průmyslové spektrum, 6/2007, s.58-59
- [9] OBMAŠČÍK, M. - TUREK, S. - JOCHMANN, A.: *Metrologia*. ALFA Bratislava 1988, 81 p.
- [10] OBMAŠČÍK, M.-TUREK, S.-ŠMÁLOVÁ, S.: *Parametre obrobeného povrchu*. In: *Obrobené povrchy: zborník z vedeckej konferencie*, Trenčín 30.-31.máj 2000. Trenčín : LUDOPRINT, 2000, s.72-77
- [11] TRENT, E. M.-WRIGHT, P.K.: *Metal cutting*. 1999, Butterworth-Heinemann, Birmingham, 439 p.
- [12] UEHARA,K.-TAKESHITA,H.: *Prognostication of the Chipping of Cutting Tools*. Annals of the CIRP vol. 38/1/1989
- [13] VENKATESH, V. C. - SATCHITHANANDAM, H. A.: *A Discussion on Tool Life Criteria and Tool* TRENT, E. M.-WRIGHT, P.K.: *Metal cutting*. 1999, Butterworth-Heinemann, Birmingham, 439 p.
- [14] ZABOROWSKI, T.: *Ekowytwarzanie*. Gorzow Wlkp.: IBEN Gorzow Wlkp., ETE Gorzow Wlkp., 2007, p.100

## AUTHORS & AFFILIATION

<sup>1</sup> MÁRIO GAJDOŠ,

<sup>2</sup> JOZEF JURKO

<sup>1</sup> ELBA A.S. KREMNICA, ČSA 264/58, 967 01  
KREMNICA

<sup>2</sup> DEPARTMENT OF MANUFACTURING TECHNOLOGY,  
TECHNICAL UNIVERSITY IN KOŠICE

---

## ***DEPENDABILITY, SAFETY AND IMPACT OF HUMAN FACTOR***

---

---

### ■ **Abstract:**

*Effective management of task dependability and safety is the necessity of a successful operation of any manufacturing system. No one wants faults to happen, but these events sometimes happen. It is one of the reasons, why engineering work on manufacturing system goes beyond ordinary maintenance and constitutes modification. Such modification involves a change in the plant or process and can introduce a wasting of wherewithal or can cause risks.*

*At the moment, a lot of problematic areas are encountered during risk evaluation. In this contribution attention is paid to identification and selection of risk and analysis of human factor.*

---

### ■ **Keywords:**

*safety management, risk, system or process modification, human factor, hazards*

---

---

### ■ **INTRODUCTION**

*The economic growth of the industry is dependent on the technological advances. The today industry means more complex processes and with very complex and complicated bonds. Because of the system complexity there are a lot of opportunities for faults and mistakes, which are caused by technical errors and by slips of human factors. The human factor is usually the most critical aspect of any manufacturing system with influence of human. For every industrial activity the producer should prevent such faults and to limit their consequences.*

*At the moment, a lot of problematic areas are encountered during faults reduction. In this contribution attention is paid to identification and selection of the most important risks (the most significant tasks) and analysis of influence of human factor.*

---

### ■ **HOW THE FAULTS ARISING**

*Faults do not happen in isolation. Rather, they are the result of a chain of events often culminating with the unsafe acts of operators. The most of faults causations has been at least partially caused by human error.*

*Howbeit the company management brings about organizational influences, which often lead to instances of unsafe supervision which in turn lead to preconditions for unsafe acts and ultimately the unsafe acts of operators. The order of analysis of unsafe acts of operators is focused at the bottom.*

---

### ■ **RISK ANALYSIS OF MANUFACTURING SYSTEM**

*The purpose of the human error analysis is to evaluate the relevant consequences to the system of the human errors identified. To get*

error probabilities of the human actions, we must take two steps in judging human reliability: in the first step, there is a collection the qualitative data about the situation to be judged. In the second step, there should be quantitatively evaluated the situation with the help of an HRA. A large number of techniques exist to quantify the probability of human failures. However, a small number of these techniques have actually been applied in practical human error analysis.

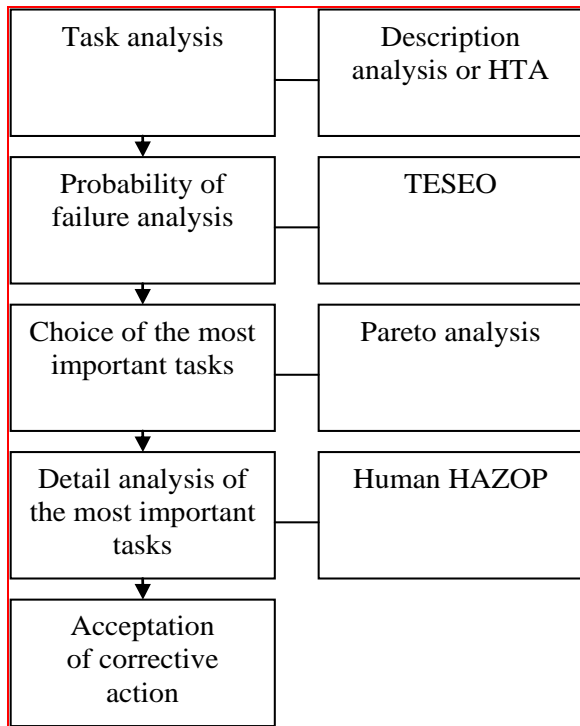

Fig. 1 Sequence of risk analysis of manufacturing system

A detailed analysis of whole manufacturing system with influence of Human factor is not possible (is very time-consuming and benefits doesn't fit the efforts). It is thus necessary to deal only with such risk sources (tasks) the consequences of which are most important. The results of the selection of tasks thus have to be transparent and have to provide an overview on the safety of all the system. From that reason the next step after task analysis and Probability of failure analysis is choice of the most important tasks.

For risk analysis of the most important tasks can be used very good method, which is used in the process industry, Human Factor Method.

## TASK ANALYSIS

First of all, it is necessary to build up a description model. It must be generally valid and it must be applicable to all observable tasks. Furthermore, the model must be able to collect all information items on human errors from the events in such a form as is necessary for an analysis because the purpose of a task analysis is to collect information on an operator activity in such a way that this information can be used in a human reliability analysis. A detailed task analysis is required for most of the human error identification techniques and human reliability analysis techniques.

Task analysis describes the demands made on the operator in the tasks he or she has to perform, and examines the resources required and available to enable the operator to meet those demands. A demand is a requirement for the operator to meet some goal which is a partial requirement for achieving a higher goal. The most significant benefit is that model can provide knowledge of the tasks that the user wishes to perform. Thus, it is a reference against which the value of the system functions and features can be tested. Description Model Method or Hierarchical Task Analysis is the most used analysis.

## PROBABILITY OF FAILURE ANALYSIS

Initially, it may be necessary to use expert judgments as a source of the probability estimates. For this purpose can be used TESEO analysis (Tecnica Empirica Stima Errori Operatori), which is a technique used in the field of human reliability assessment, for the purposes of evaluating the probability of a human error occurring throughout the completion of a specific task.

Conclusions from such analyse can then be used to choice of the most important tasks (with using for example Pareto analysis 80/20).

The technique of TESEO is typically quick and straightforward, it is useful in identifying the effects improvements in human factors will have on the overall human reliability of a task.

---

■ **DETAIL ANALYSIS OF THE MOST IMPORTANT TASKS**

---

*When we want to reduce the likelihood of errors occurring within a system improve the overall levels*

*of dependability, we have to come up with detail analysis of the most important tasks (from the previous paragraph). Ideal for this objective is method Human HAZOP*

*The method is similar to the well proven HAZOP study for assessing new process design, but focussing on the sequence of actions carried out during a critical tasks.*

*The key steps in the activity are identified with an experienced operator followed by a team based study to identify potential human failures at each step, using appropriate guidewords.*

*The key benefits of Human HAZOP are comprehensiveness, systematicness and effectiveness. Human HAZOP ensures that potential deviations from intended task procedure are identified and corrected, process hazards are revealed and actions for necessary process or instrumentation improvements can be planned.*

---

■ **CORRECTIVE ACTION**

---

*After Human HAZOP analysis, which gives us the list of arrangements, we have to implement change to cope a weakness identified in a management system. Candidates for preventive action can result also from suggestion of TESEO analysis.*

*We should try to improve rather than a simple react to identified problems, the preventive action might involve analysis of data, including trend and risk analyses and proficiency-testing results.*

---

■ **CONCLUSION**

---

*The prevention of faults is the only possible and rational approach for managed manufacturing system.*

*Edification for management is needed (especially for medium enterprises). Each employee must have appropriate training, must be well informed about process must be prepare to right and quick reaction. For all that the faults still happen.*

*The functional dependability and safety management system requires that risk responsibility and accountability will be reduced. The human factor is usually the most critical aspect of any manufacturing system with influence of human factor.*

*The sequence of risk analysis of manufacturing system contained on the fig. 1 was checked up practically. It demonstrates that the risks associated with failures of critical procedures can be systematically reduced. The method could be applied retrospectively to existing operations or be used during the design stage of new systems.*

---

■ **ACKNOWLEDGMENT**

---

*This paper was created with support of research objective MŠMT 1M06047 The Centre of Quality and Reliability.*

---

■ **REFERENCES**

---

- [1.] KIRWAN, B., 1994, *A Guide to Practical Human Reliability Assessment*. Taylor and Francis, London.
  - [2.] KOTEK, L., BABINEC, F., 2005, *Fulfill of Requirements on Increasing of Employees Safety in Fire Risk Environment*. Ropa, uhlie, plyn a petrochémia. 47, 1-2, pp. 18-21.
  - [3.] KOTEK, L., PUSKEILEROVÁ, L., 2005, *Connection of Change Management and Human Factor*. In *Proceedings of the XII international scientific-technical conference Trans & MOTAUTO'05+*. Sofia, Scientific-technical Union of Mechanical Engineering, pp. 100 – 102
- 

■ **AUTHORS & AFFILIATION**

---

<sup>1</sup> LUBOŠ KOTEK

<sup>1</sup> INSTITUTE OF PRODUCTION MACHINES, SYSTEMS AND ROBOTICS, FACULTY OF MECHANICAL ENGINEERING, BRNO UNIVERSITY OF TECHNOLOGY, CZECH REPUBLIC



---

## **MATHEMATICAL MODEL OF TECHNOLOGICAL PROCESSES WITH PREDICTION OF OPERATING DETERMINING VALUE**

---

---

### ■ **Abstract:**

*The paper describes a development of a new approach to simulation of dimensional wear of cutting tool with subsequent element of correction in limits of parametrically given optimal shifts. The article describes aspect belonging to polynomial transformation of experimentally given discrete values of knife point position and their subsequent integrity into continuous functional form compatible with used software.*

---

### ■ **Keywords:**

*optical scanner, turning, approximation, regulation, monitoring*

---

---

### ■ **INTRODUCTION**

*Present could be characterized as the time of ever increasing requirements and demands for automated production facility. New principles and technologies are preferred especially in the area of supervision, regulation and control. In the area of machining are particularly addressed issues of measurement and correction of dimensional wear of cutting tool. The analysis of literary sources shows, that, because of application in the operating conditions, it is necessary to focus on indirect methods of active supervision, among which a perspective method seems to be the method of detection of blunting of cutting tools from changes of workpiece dimensions. But the geometry of a lathe blade changes in the course of usage because of wear. Wear is the loss of the original geometric shape of a cutting wedge. It may also be connected with the change of mechanical properties. The resulting dimensional wear of the cutting tool*

*can be corrected by corrective movement of the lathe blade towards the workpiece by amount of wear. A sensor measures dimensions of a workpiece and the measured values are gradually feed into an evaluation device [2].*

---

### ■ **DESCRIPTION OF EXPERIMENTAL MEASURING PRINCIPLE**

*Measuring of dimensional wear of a cutting tool using a temperature sensor was developed on the basis of so far known very good properties of temperature sensors verified by measuring. From these results, that temperature sensors working with the change of heat output have dependence characteristics between the heat output  $\Phi$  of the scanned part and electrical resistance. The method of dimensional wear measuring of cutting tools is significant for the fact, that during blunting of a knife there is increase in cutting force and thus increase in the creation of heat during lathe-turning. The Sensor*

consists of a temperature-dependent resistor placed on the lathe blade. Position of the sensor on the blade constant to preserve the value of time constant  $\tau$ , which is needed for further calculations. Amount of stabilized temperature during lathe-turning provides the information about tool wear. For a given type of an instrument it is necessary to measure the dependence of temperature on wear; measuring during operation is reliable, when the same parameters are ensured, particularly the preservation of the approximate hardness of machined materials. This measurement principle considers only static parameters; a dynamic system is being developed, with successful test results so far [1].

■ **PROCESS AND CONDITIONS OF EXPERIMENTAL SIMULATION**

Modelling of the system ran discretely with sampling with a specific frequency. During the simulation, a maximum limit value of the temperature, which the knife would reach if the rise or fall in temperature followed the same trend, is calculated from two immediate values of measured temperature. Since the curve of dependence of blade wear on the temperature during lathe-turning is measured continuously, the temperature has continuous course as well. In practical machining, however, there often are interruptions of the process. As a result, the temperature value sharply changes. During a longer interruption of machining the temperature drops to ambient temperature value (in the simulation it is the value of 23 °C) and several minutes can pass from the start of machining until relative stabilization of the temperature. Therefore, if the determination of tool wear was based on only one immediate temperature value, it would cause great inaccuracy in the determination of tool wear. Since the rise and drop in body temperature is a phenomenon that can be expressed mathematically, it is possible to determine a fixed value that we need to know from two consecutive temperature values.

It is possible to express the phenomenon in question by static system differential equation with delay of 1<sup>st</sup> degree. The general form of this equation is as follows:

$$J \frac{dx}{dt} + x = ky \tag{1}$$

where  $x$  is a variable and  $J$  is a constant [3].

The course of increasing temperature in dependence on time is expressed by the formula (2):

$$T_1 = T_N \cdot \left( 1 - e^{-\frac{t_1}{\tau}} \right) \quad \text{and} \quad T_2 = T_N \cdot \left( 1 - e^{-\frac{t_2}{\tau}} \right) \tag{2}$$

where:

$T_N$  is the limit temperature value in measurement point, which can the cutting tool reach, if the temperature in the spot of cut don't change

$T$  – immediate temperature in the measurement point

$t$  – time of temperature value detection,

$\tau$  - time constant.

The time constant is a constant value for the given cutting tool and measurement point. It is necessary to know maximum trend value of temperature in each point for the correctness of measuring. For that it is necessary to measure the temperature of two consecutive measurement points  $t_1, t_2$ :

Since after expression  $t_1$  and  $t_2$  the difference  $\Delta t = t_2 - t_1$  is a known value, it is possible to express  $T_N$  as follows:

$$T_N = \frac{T_1 - T_2 \cdot e^{-\frac{\Delta t}{\tau}}}{1 - e^{-\frac{\Delta t}{\tau}}} \tag{3}$$

This expression allows to determine the limit value of temperature in every point of measurement on the basis of known variables, and to accelerate the determination of the immediate value of cutting tool wear.

The simulation of given expression was conducted using simulation model shown in Fig. 1.

In Fig. 1 is the block scheme of the simulation model necessary for the process of determination of predictive limit value of dynamically changing temperature in actual operation. The model contains an experimental generator of temperature course with the possibility to set individual parameters. Another part consists of the block realisation of mathematic function for the calculation of limit



temperature. Since it is necessary to use two temperature samples in the formula, the second sample is defined on the basis of delay, but in the real time of process simulation. An appropriate element was a discrete delay block, output course of which is shown in Fig. 2.

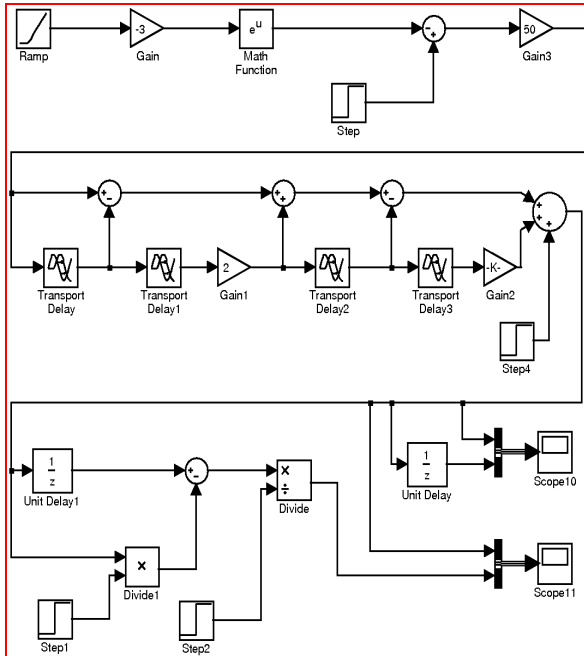

Fig. 1 Simulation model of determination of predictive limit temperature.

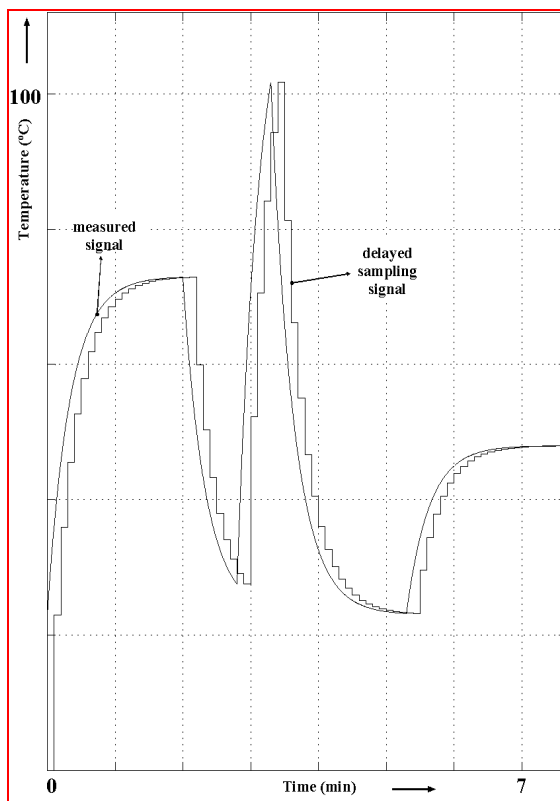

Fig. 2 Course of temperature simulation value and sampling signal with transport delay

It can be seen on the graph in Fig. 2, which at the time of temperature raise the difference of the measured temperature and predictive limit temperature is relatively large and is gradually decreasing. The wear value of the cutting tool would be determined incorrectly during transient process, if it was based only on the value of immediate measured temperature. It is therefore necessary to have two measured values of immediate temperature, which will allow calculating the limit temperature. All step points of sampling signal course in the graph are points at which the predictive limit temperature is updated.

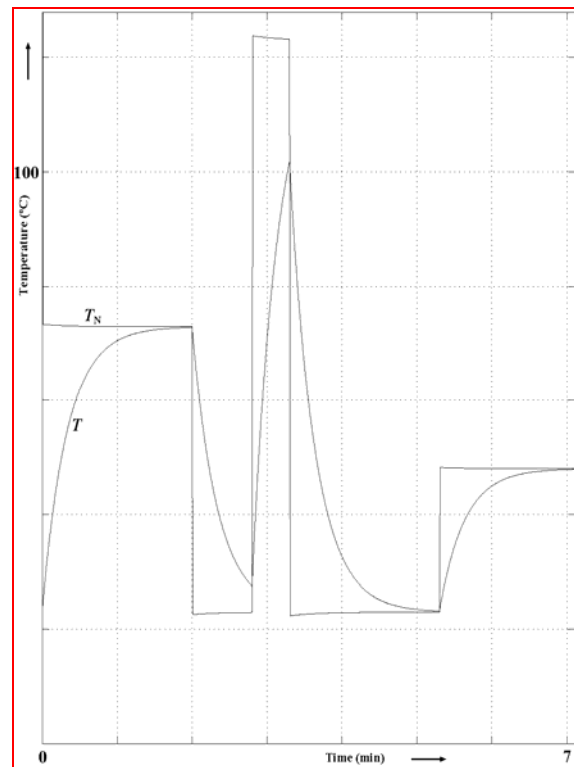

Fig. 3 Graph of dependence of temperature simulation value  $T$  on time and its prediction limit value  $T_N$ .

Fig. 3 shows the dependence of temperature simulation value  $T$  on time and its prediction limit value  $T_N$ . At the 2nd minute there was a reduction of heat at the spot of the cut and it was reflected by the changed slope of the increase of measured temperature. This change could be caused by the change of workpiece hardness, or change of other machining parameters. At the time of 2.75 mines, there was again a change of machining parameters. Heat creation at the cut spot increased, which caused steeper temperature increase as opposed to previous

increase in the 0 – 2 minutes interval. The predictive limit temperature was, however, determined on the basis of the calculation in the time of generation of the second sample of sampling signal since the beginning of the change. This method allows fast determination of end limit temperature in the area of frequent temperature changes, which is decisive for the evaluation of tool condition. By processing of measured condition of cutting tool it is possible to realize wear correction of given tool in the form of correction shift in the next step. It is very beneficial to verify the functionality of such regulating system by creation of its model and simulation model in an appropriate simulation environment.

Given method of determining the limit temperature measurement in processes of measurement and regulation enables to make the information on process immediate condition more accurate using this determining variable, especially for the reason of its continuous dynamics. In this way it is possible to accurately determine the temperature limit value in every moment and during frequent changes of machining parameters, which create inharmonic dynamism of temperature flows. Without this principle of limit value determination, the whole process would contain a discrete error within the transport time delay pertaining to directly proportional time constant of heat transfer.

## CONCLUSION

This mathematical model is an elemental result of solution of complex measurement and control system with partial mutually elements which are signally tied. In the process of supervision of manufacturing operation related to a single temperature parameter it is necessary to achieve a state of collection of discrete values in real time, especially if there is data processing in a comparative way. This method includes a reference member, whose values pertain to immediate states without transport delay. It is still necessary to take into account the size of introduced error in the area of dynamic changes under the influence of transport delay under the influence of prediction. There are ways of correction with prediction of immediate limit value on the basis of gradient and its changes also in the systems with transport delay.

However, this method is computation-time intensive in the area with higher dynamics, since the sampling frequency increases with the dynamics of the defining variable in order to maintain the required accuracy.

## ACKNOWLEDGMENT

The contribution presents the part of solution of the grant task VEGA No. 1/0562/08 | 5 |

## REFERENCES

- [1.] KLÁN, P., GOREZ, R.: *Balanced Tuning of PI Controllers*, *European Journal of Control* 6 (2000), 541-550.
- [2.] SVETLÍK, JOZEF et al.: *Inteligentný montážny systém*. In: *Acta Mechanica Slovaca*. roč. 7, č. 3 (2003), s. 145-148. ISSN 1335-2393.
- [3.] ZHOU, J., ANDERSSON, M., STAHL, J: *A System for Monitoring Cutting Tool Spontaneous Failure Based on Stress Estimation*, *J. of Materials Processing Technology* 48 (1995), 231-237.

## AUTHORS & AFFILIATION

<sup>1</sup>RADOSLAV KREHEL,

<sup>2</sup>JOZEF DOBRÁNSKY,

<sup>3</sup>TIBOR KRENICKÝ

<sup>1..2..3</sup>KATEDRA PREVÁDZKY VÝROBNÝCH PROCESOV,  
DEPARTMENT OF MANUFACTURING PROCESSES  
OPERATION, TECHNICAL UNIVERSITY IN KOSICE,  
SLOVAKIA

---

## ***HIGH-VELOCITY WATER JET IMPACT ON CONCRETE SAMPLES***

---

---

### **■ Abstract:**

*The concrete samples with various erosion states were disintegrated inside the overpressure vessel using high-velocity water jet and depth of penetration was measured. Removing of the eroded parts of samples was also tested using low-pressure generated continuous or pulsing fan jets and rotating jets. The influence of the erosion states, water jet techniques, traverse rate and stand-off distance on the disintegration volume was studied and the surface topography was investigated. The high-pressure generated continuous water jet was applied in the overpressure vessel used for simulation of pressures equivalent to the submersion to several depths under the water level. The low-pressure generated continuous or pulsing jets were applied in air conditions. Some samples of special decorative concretes were also studied.*

---

### **■ Keywords:**

*water jet, concrete, depth of penetration, disintegration volume*

---

---

### **■ INTRODUCTION**

*The first serious approach to water jet use for concrete cutting was probably performed by McCurrich and Browne (1972). The water-jet techniques are widely used for cleaning, profiling, removal, drilling and demolition of concrete substrates (Momber, 1998). Research presented in this paper is aimed at the influence of the erosion states, water jet techniques, traverse rate and stand-off distance on the disintegration volume. The depth of penetration of the submerged water jets into the concrete samples was also measured. The samples were prepared in special laboratories of the Faculty of Civil Engineering of the Technical University in Brno and they are used for simulation of chemical plants, sewages, aggressive*

*underground waters and many more corrosive media. Except the most common concretes used for constructions some special samples of decorative concretes were tested.*

---

### **■ DESCRIPTION OF EXPERIMENTAL MATERIAL**

*The experimental blocks were prepared from several types of the high-strength concrete characterized by the cement type CEM I 42.5; the water coefficient 0.4. The gravel aggregate was Moravian wacke from locality Bohučovice with fractions 0-16 mm. The average specific density of the concrete is 2750 kg·m<sup>-3</sup> and the average uniaxial compression strength is 62.8 MPa. These samples are referred as "Concrete type III". Other blocks were prepared as a standard concrete sort B30 (according to the Czech*

norms); the stone fraction 0-4 mm is from the locality Ledce, the stone fraction 8-16 mm is from the locality Olbramovice, the stone fraction 11-22 mm is from the locality Lomnička and the plasticizer Sikament 100 is used. All stone localities are in the Czech Republic. These samples are referred to as "Concrete type II". They were separated into several groups. The first one was the reference group stored in common indoor air conditions. The second group of samples was stored in the lotion with a high concentration of the  $\text{NH}_4^+$  ions (up to 4%) simulating aggressive media in chemical industry or in sewage canals and other structures. The third group of samples was stored in the lotion with the  $\text{Na}_2\text{SO}_4$  (concentration of the  $\text{Na}_2\text{SO}_4$  is 51.2 grams per liter of water) simulating thus media in aggressive setting (chemical and sewerage plants, groundwater rich in concentration of sulphates). The fourth group of samples was stored in a special container with a high concentration of the  $\text{CO}_2$  gas and the relative humidity 90% - these conditions simulate the process of concrete carbonation in air due to the  $\text{CO}_2$  influence in combination with the air humidity or they simulate activity of the aggressive  $\text{CO}_2$  from the groundwater. The fifth group of samples was stored in the solution of the NaCl in water (100 grams per liter) simulating aggressive media in the sewerage plants, in the water treatment plants or in the pools with the chlorinated water. The sixth group of samples was exposed by several tenths of freezing and de-freezing cycles. The lotions were changed each two months and their pH factors were tested each fourteen days.

The concrete samples referred as "Concrete type I" were prepared from concrete used for outdoor medium loaded planes built before 1989. The exact structure is not known but it is a concrete with rather small size stones.

Some samples were prepared in the Research Institute of Building Materials, Inc., Brno, Czech Republic. These concretes (BP1, BP2, BP3) were prepared using fine sands, instead of the usual gravel aggregate, some pigments and special fabrics acting like the reinforcement (silicon fibers in one plane or silicon based tissue). They are used specially as the decorative concretes inside and outside the industrial buildings.

## EXPERIMENTAL PROCEDURE

Concrete samples were tested in the overpressure vessel produced several years ago (Hlaváč et al., 2001). The samples were approximately 150 x 100 x 50 mm. In the beginning of each experiment the respective block was fixed into the support of the motional device inside the pressure vessel (Fig. 1). The vessel was closed and filled with water except the case when the tests were performed in air for comparison. Water inside the vessel was either without any pressure or pressurized. The overpressures were set from zero up to 1.4 MPa with the 0.2 MPa step.



Fig. 1. Support with sample in front of the pressure vessel

Pressurizing of the water inside the chamber was supplied by the inflow from the cutting nozzle and by the regulation overflow valve. The water pressure inside the vessel was measured using the mechanical pressure meter installed at the vessel body. The kerfs were performed at various traverse rates. Pump pressure was 380 MPa, the nozzle diameter was 0.25 mm, the stand-off distance was 10 mm (from the nozzle outlet) and the angle between the jet axis and the normal to the impingement surface of the samples was 0 rad. The depths of kerfs were measured in five points assigned on the respective sample surfaces and the average values of the depth of all kerfs were evaluated. The experimental results were then fitted by means of polynomial regression. The  $A_k$  coefficient was selected as the criterion for the optimal order of the polynomial (Anděl, 1998).

The multivariate analysis of variance (MANOVA) was used to judge whether changes in factors like erosion state, water jet technique, traverse rate and stand-off distance have the significant effects on the disintegration volume.

Simultaneously, some experiments with the low-pressure based water jets were performed either with nozzles Lechler 1508 having the outlet diameter 2.05 mm and producing fan jets with vertex angle 30° or with the rotating head Barracuda carrying two nozzles with outlet diameter 1.19 mm. The nozzle inlet diameter was 4 mm in both cases. Water pressure was 30 MPa, the stand-off distance was 20, 40 or 50 mm and the amplitude of vibrations was 7 μm if applied. The experiments were performed with traverse rates 100, 200, 400 and 1000 mm per minute. The disintegrated volume was determined for the length 150 mm that corresponds to the dimension of the sample. Typical width of the fan jet trace on the material surface was 22 mm, and about 30 mm for head Barracuda. The depth of penetration altered from about 1 mm without pulsing up to more than 10 mm with pulsing switched on.

**RESULTS AND DISCUSSION**

The results obtained on the construction concretes without any additional treatment are presented in Fig. 2. The results obtained on the construction concrete samples remitted to the influence of various aggressive media are shown in Fig. 3. The cutting results from tests performed on decorative concretes are summarized in Fig. 4. Some of the results are the anticipated ones. The decrease of the depth of penetration with increasing overpressure inside the vessel is one of the most expected ones. The reduction of the penetration efficiency was expected also for concretes with the large-size stones. This presumption was confirmed partially (Fig. 2) but not fully. The large volume disintegration occurred (Fig. 3) and so the measurement of the depth of penetration of water jet into the concrete sample was made very difficult. It is evident, that measurement of the depth of penetration should be modified or replaced by another characteristic parameter, e.g. disintegrated volume.

The decorative concretes are rather cut than volume disintegrated. Therefore, the rapid decrease of the depth of penetration (Fig. 4)

measured for increasing overpressure inside the vessel can be hardly influenced by some large breaks on the sample surface. So, the dominant role seems to be played by the fibrous base. The fibers were prepared as planes from various materials and their positions inside the concretes were varying. The elasticity of such fibrous base and its non-homogeneity can explain behavior of the samples from the decorative concretes satisfactorily.

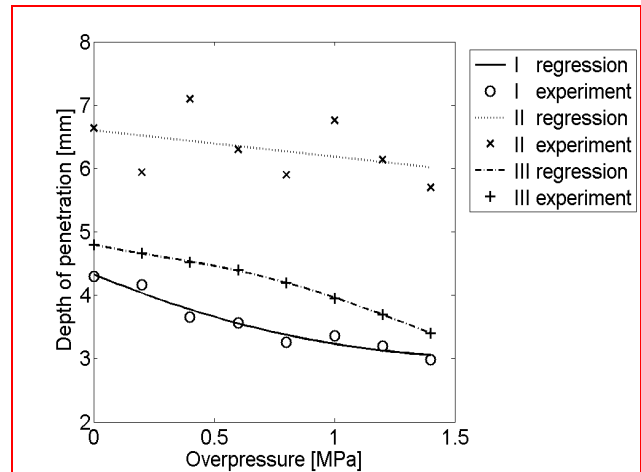

Fig. 2. Effect of overpressure in the vessel on depth of penetration for construction concretes without any additional treatment (I, II and III – types of the concrete); The orders of the polynomial fitting are: I – 2, II – 1, III – 4

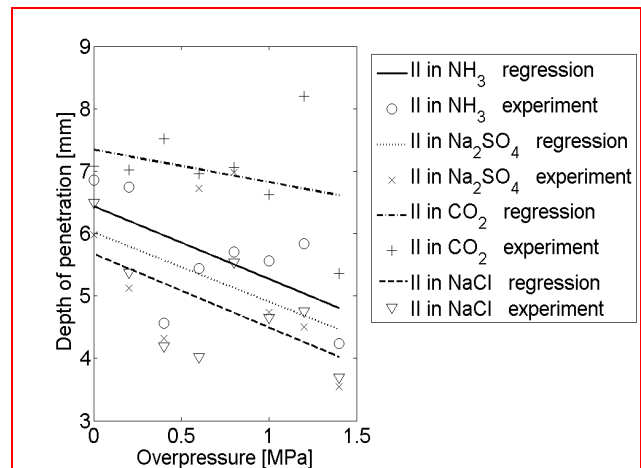

Fig. 3. Effect of overpressure in the vessel on depth of penetration for samples prepared from concrete II and submitted to various chemical influences. The order of the polynomial fitting is 1

The significant effect of the traverse rate, water jet technique and erosion state on the disintegration volume was demonstrated by means of the F-test value on the significance level  $\alpha = 0.05$  (Tab. 1). Experimental data set applied is presented in Tab. 2.

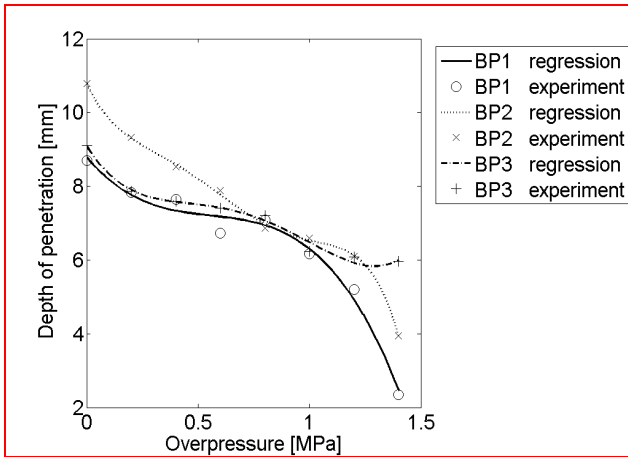

Fig. 4. Effect of overpressure in the vessel on depth of penetration for construction decorative concretes. The orders of the polynomial fitting are: BP1 – 3, II – 5, III – 4

Multivariate analysis of variance is performed for disintegrated volume of samples presented in Tab. 1. Source term is the source of variation in the model. The abbreviation DF means the degrees of freedom, i.e. the number of observations corresponding to this term. The sum of squares represents the sum of squares for this term and the mean square is the sum of squares divided by the degrees of freedom. The label F-ratio means the F-test value, while prob. level is the significance level of the F-ratio. Power ( $\alpha = 0.05$ ) means the probability of rejecting the hypothesis that the means of the disintegrated volume in different groups are equal when they are in fact not equal. Photo of some samples of construction concretes is presented in Fig. 5. It demonstrates variation in the water jet effects with increasing depth of submersion.



Fig. 5 Selected samples of construction concretes

Tab. 1. Analysis of variance table for disintegrated volume

Source Term	DF	Sum of Squares	Mean Square	F-Ratio	Prob. Level	Power ( $\alpha = 0.05$ )
Sample	6	4614.796	769.132	4.90	0.0003*	0.9869
Technique	3	2625.653	875.217	5.57	0.0017*	0.9512
Rate	3	3860.037	1286.67	8.19	0.00009*	0.9892
Distance	2	6.43051	3.21525	0.02	0.97973	0.0529
Nozzle diameter	1	0	0	0	1	0.05
S	71	11149.4	157.034			
Total (Adjusted)	86	26107.7				
Total	87					

\* Term significant at  $\alpha = 0.05$

Tab. 2. Analyzed concretes (RCH: reference CH, C: CHRL 100, F: freeze 100, NaCl: chloride, SO4: sulfate, R: reference, N: NH3)

Sample	Water-jet Technique	Traverse Rate (mm/min)	Stand-off Distance (mm)	Nozzle Diameter (mm)	Disintegrated Volume (cm <sup>3</sup> )
RCH	FP	200	40	2.05	24.0
RCH	FC	200	40	2.05	6.0
C	FC	200	40	2.05	22.0

Tab. 2. Analyzed concretes (RCH: reference CH, C: CHRL 100, F: freeze 100, NaCl: chloride, SO4: sulfate, R: reference, N: NH3) [continuing]

Sample	Water-jet Technique	Traverse Rate (mm/min)	Stand-off Distance (mm)	Nozzle Diameter (mm)	Disintegrated Volume (cm <sup>3</sup> )
RCH	FP	400	40	2.05	21.0
RCH	FC	400	40	2.05	6.0
C	FP	400	40	2.05	30.0
C	FC	400	40	2.05	26.3
C	FP	200	40	2.05	31.7
RCH	FP	100	40	2.05	29.3
RCH	FC	100	40	2.05	9.8
C	FP	100	40	2.05	28.3
C	FC	100	40	2.05	22.5
C	RP	400	50	1.19	50.0
C	RC	400	20	1.19	23.6
RCH	RP	400	50	1.19	22.0
RCH	RC	400	20	1.19	7.0
RCH	FP	1000	40	2.05	15.0
RCH	FC	1000	40	2.05	2.3
C	FP	1000	40	2.05	21.0
C	FC	1000	40	2.05	7.5
C	RP	1000	50	1.19	39.4
C	RC	1000	20	1.19	24.4
RCH	RP	1000	50	1.19	17.5
RCH	RC	1000	20	1.19	6.3
RCH	RP	100	50	1.19	48.8
RCH	RC	100	20	1.19	8.8
RCH	RP	200	50	1.19	23.8
RCH	RC	200	20	1.19	3.7
F	FC	400	40	2.05	60.0
F	FP	400	40	2.05	112.5
F	RP	400	50	1.19	27.3
F	RC	400	20	1.19	13.5
F	RP	1000	50	1.19	18.8
F	RC	1000	20	1.19	6.8
F	RP	200	50	1.19	46.0
F	RC	200	20	1.19	23.7
F	RP	100	50	1.19	49.0
F	RC	100	20	1.19	43.5
NaCl	FP	400	40	2.05	22.5
NaCl	FC	400	40	2.05	6.8
NaCl	FP	100	40	2.05	27.0
NaCl	FC	100	40	2.05	9.0
NaCl	FP	200	40	2.05	24.0
NaCl	FC	200	40	2.05	8.3
NaCl	FP	1000	40	2.05	19.5
NaCl	FC	1000	40	2.05	5.0
SO4	FP	400	40	2.05	17.8
SO4	FC	400	40	2.05	5.0
SO4	FP	100	40	2.05	33.0

SO4	FC	100	40	2.05	12.0
SO4	FP	200	40	2.05	21.0
SO4	FC	200	40	2.05	6.0
SO4	FP	1000	40	2.05	13.5
SO4	FC	1000	40	2.05	3.0
R	RP	400	50	1.19	35.0
R	RC	400	20	1.19	18.8
R	RP	1000	50	1.19	20.0
R	RC	1000	20	1.19	10.0
R	RP	100	50	1.19	47.5
R	RC	100	20	1.19	41.3
R	RP	200	50	1.19	42.5
R	RC	200	20	1.19	17.5
NaCl	RP	400	50	1.19	41.3
NaCl	RC	400	20	1.19	11.3
NaCl	RP	1000	50	1.19	10.0
NaCl	RC	1000	20	1.19	6.3
NaCl	RP	100	50	1.19	50.0
NaCl	RC	100	20	1.19	36.3
NaCl	RP	200	50	1.19	55.0
NaCl	RC	200	20	1.19	35.0
SO4	RP	400	50	1.19	21.3
SO4	RC	400	20	1.19	7.5
SO4	RP	1000	50	1.19	16.3
SO4	RC	1000	20	1.19	4.4
SO4	RP	100	50	1.19	41.3
SO4	RC	100	20	1.19	13.8
SO4	RP	200	50	1.19	30.0
SO4	RC	200	20	1.19	15.0
N	RP	400	50	1.19	23.8
N	RC	400	20	1.19	20.0
N	RP	1000	50	1.19	30.0
N	RC	1000	20	1.19	11.3
N	RP	400	20	1.19	40.0
N	RP	100	50	1.19	53.8
N	RC	100	20	1.19	45.0
N	RP	200	50	1.19	30.0
N	RC	200	20	1.19	11.3

### CONCLUSION

The disintegration decreases with the depth of submersion and that water jets in deeper submersion act like the ones generated from lower pressure in the air medium. The influence of the concrete aging in special solutions on the cutting ability of the submerged water jet was not proved. The disintegrated volume can be applied for estimation of water jet efficiency.

### ACKNOWLEDGMENT

The authors are grateful to the Czech Science Foundation for support by the project 103/07/1662.

---

■ REFERENCES

---

- [1.] MCCURRICH, L.H., BROWNE, R.D. *Application of water jet cutting technology to cement grouts and concrete. In. Proc. 1<sup>st</sup> Int. Symp. Jet Cutting Technol. (ed. T.E. Brock, A. Richardson), BHRA, Cranfield, G7/69-G7/91, 1972.*
- [2.] MOMBER, A.W.: *Water Jet Applications in Construction Engineering, A.A. Balkema, Rotterdam, 1998.*
- [3.] HLAVÁČ, L.M., HLAVÁČOVÁ, I.M., KUŠNEROVÁ, M., MÁDR, V. *Research of Waterjet Interaction with Submerged Rock Materials. In: HASHISH (ed.): Proceedings of the 2001 WJTA American Waterjet Conf. WJTA, St. Louis, Missouri, Vol. II, pp. 617-624, 2001.*
- [4.] ANDĚL, J.: *Statistické metody, Matfyzpress, Praha, 1998.*
- 

■ AUTHORS & AFFILIATION

---

- <sup>1</sup> VILÉM MÁDR,  
<sup>2</sup> RADIM UHLÁŘ,  
<sup>3</sup> LIBOR M. HLAVÁČ,  
<sup>4</sup> LIBOR SITEK,  
<sup>5</sup> JOSEF FOLDYNA,  
<sup>6</sup> RUDOLF HELA,  
<sup>7</sup> LENKA BODNÁROVÁ,  
<sup>8</sup> JIŘÍ KALIČINSKÝ

<sup>1..2...3..8.</sup> INSTITUTE OF PHYSICS, FACULTY OF MINING AND GEOLOGY, VŠB - TECHNICAL UNIVERSITY OF OSTRAVA, CZECH REPUBLIC

<sup>4..5.</sup> INSTITUTE OF GEONICS, CZECH ACADEMY OF SCIENCES, OSTRAVA, CZECH REPUBLIC

<sup>6..7.</sup> INSTITUTE OF TECHNOLOGY OF BUILDING MATERIALS AND COMPONENTS, TECHNICAL UNIVERSITY OF BRNO, CZECH REPUBLIC



---

## **PROJECT INTER-COUNTRIES RESEARCH FOR MANUFACTURING ADVANCEMENT (IRMA)**

---

---

### ■ **Abstract:**

The project *Inter-countries Research for Manufacturing Advancement (IRMA)* is focused to the realization of a research and comparative analysis in the 27 European Union's member states, aimed at promotion of excellence and efficiency of the instruction in higher education institutions. The IRMA project is research on the manufacturing engineering field, taken into consideration its high level of innovation and fast changes in requirements that students must possess, in order to be adapt and competitive on the labour market. The objectives of the IRMA project is to innovate and to improve educational systems of technical universities at European level, in order to offer to students a competitive environment based on innovative teaching methods, instruments and contents.

---

### ■ **Keywords:**

*Lifelong Learning Programme, research in manufacturing*

---

---

### ■ **INTRODUCTION**

The international project *Inter-countries Research for Manufacturing Advancement (IRMA)*, co-financed within the *Lifelong Learning Programme*, consists in realisation of a 2-years *Research-Comparative Analysis in the 27 European Union's Member States*, aimed at the promoting excellence, efficiency and fairness of the instruction in Higher Education Institutes within the *Manufacturing Engineering* sector. The above sector was selected since it is supposed to contain a high level of innovation and quickly-changing requirements that students should possess in order to adapt themselves and be competitive in the labour market.

The *Research Analysis* involves three Interfaces: *Enterprises, Universities, and "Intermediary" Institutions (Incubators, Technological Poles,*

*Academic Spin-off, Institutional Agencies)*. The analysis focuses on the following activities:

- to understand what competences and knowledge are demanded by Enterprises,
- to understand what competences and knowledge are supplied by Universities,
- to understand what competences and knowledge are spread by Intermediaries.

Duration of the IRMA Project is 24 months (01/01/2008 – 31/12/2009) and is carried out in the following phases:

- 1.] Preparation and Design of Project ICT instruments.
- 2.] Research Analysis Realisation.
- 3.] Realization of Quality, Evaluation and Validation Plan.
- 4.] Dissemination.
- 5.] Exploitation.

The data are collected through a web questionnaire, specific for every one of the three Interfaces, and put in a Data Base created on a Portal. The following criteria are compared at the European level, as declared within the Project IRMA:

qualitative and innovation level of teaching in the higher education, quantitative level of students, causes/rate of scholastic defection, preventive actions for scholastic defection, European mobility, occupational way out, skills and competences management, obstacles to access/change/transfer to another faculty, e-learning services [1].

The analysis allows a detailed comparison among various Universities that have the opportunity to exchange best practice and innovative elements existing in their own educational systems. The above-mentioned database – including all gathered data through web questionnaires – will be available on the Lifelong Learning Manufacturing Portal - LLMP. The Portal is used during the project realisation, and most of all, after its end as a place where to communicate and to exchange information and knowledge about manufacturing in an “open logic”.

---

**■ PARTNERS IN THE IRMA PROJECT**

---

*Partner 1 - Project applicant and beneficiary: The Faculty of Manufacturing Technologies of the Technical University of Košice with a seat in Prešov was established in 1992. Tradition of university technical education in Prešov started in 1979 by branch of the Faculty of Mechanical Engineering of TU of Košice. Despite its short existence, the Faculty of Manufacturing Technologies has built up a firm position among the faculties of technical universities in Slovakia. More than 1600 students study at the faculty in various forms of studies and each year more than a hundred students are graduated from the faculty [3]. Role of the Faculty of Manufacturing Technologies in the project: Project Strategy Guidelines preparation (detailed planning) in EN language, preparation proposal for detailed economic planning among partners, specification of equipment (purchased from the project budget), preparation of draft Analysis Format proposal, establishment of communication and administrative system,*

*definition of requirements specification for the LLP on manufacturing, project management.*

*Partner 2 - Project coordinator: Gruppo CS Torino (Italy) is a small enterprise that belongs to Gruppo CS, a company that deals with consulting, education and training at national and international level, through structures located in different Italian areas, including a local office abroad strategically situated in Bratislava. Gruppo CS training activities (traditional and distance Learning) are the realization of: longlife learning courses for employed persons of the about 2000 companies of his consortium; higher education courses, projects and training activities in the field of high technical superior education and training courses realized in cooperation with intermediate schools, educational agencies and universities, European projects in various fields such as education, ICT, long distance work, etc. Role of the Gruppo CS in the project: management and coordination, TSCC meetings, preparation and design project, research and analysis, evaluation, dissemination, exploitation.*

*Partner 3 – University of Oulu (Finland) is one of the largest universities in Finland with an exceptionally wide academic base. Internationally pioneering research is conducted as a collaboration of different disciplines. The University cooperates closely with industry and commerce, and has broad connections with hundreds of international research and educational institutions. Six faculties and their departments form a multi-disciplinary academic community that enables diversified studies based on multifaceted research. Role of the University of Oulu in the project: participation on TSCC meetings, preparation and design project ICT, research and analysis, quality, evaluation, validation, dissemination, exploitation.*

*Partner 4 – Poznan University of Technology, Poznan (Poland) is one of the top rated research and educational institutions in Poland. The Faculty of Mechanical Engineering and Management (FMEM) was established in 1974. Now it is one of 9 Faculties of Poznan University of Technology. The FMEM mission is to provide graduate and undergraduate education and to conduct research in information and communication technologies. Our curriculum provides students with a superb background for careers in an increasingly technological society. Role of the Poznan University of Technology in*

*the project: participation on TSCC meetings, preparation and design project ICT, research and analysis, quality, evaluation, validation, dissemination, exploitation.*

*Partner 5 – North University of Baia Mare (Romania) has been functioning since 1990 has the following main domains (majors) undergraduate studies: Industrial Engineering, Mechanical Engineering, Economic Engineering, Computers and Information Technology, Electronics and Telecommunications. The Faculty coordinates the fundamental research activity, ensures the students' fundamental training in every major, takes part in the higher education entrance examination, closes research contracts with specialists from Romania or from abroad. Role of the North University of Baia Mare in the project: participation on TSCC meetings, preparation and design project ICT, research and analysis, quality, evaluation, validation, dissemination, exploitation.*

*Partner 6 – Balear de Desarrollo y Formación, Palma (Spain) is an ICT research and development, training and consultancy company. BDF collaborates with organisations and institutions involved in R & D, adult education and training, employment etc., contributing to the building of the Knowledge Society by developing innovative adult education, lifelong learning, training and IT systems, programmes, products, services and methodologies. Role of the BDF in the project: participation on TSCC meetings, preparation and design project ICT, research and analysis, quality, evaluation, validation, dissemination, exploitation.*

*Partner 7 – Studio TEOS, Milan (Italy) was founded in 1982 carried on activities of research for the University of Milan. Studio TEOS deals with projects and consulting in ICT field with particular reference to Internet communication, e-Learning and workgroup, and has specific expertise and experience in: design and development of applications and portals that organize services and digital objects coming from distributed and heterogeneous repositories, use of the new technologies in the organizational processes and training systems. Role of the Studio TEOS in the project: participation on TSCC meetings, preparation and design project ICT, research and analysis,*

*quality, evaluation, validation, dissemination, exploitation.*

*Partner 8 – CAD-Up International s.r.o. Prešov (Slovakia) has been founded in 1994. The main activities are oriented for support CAD/CAM/PLM products and engineering projects for machinery companies in Slovakia - especially for mould producers, special tools producers. The firm is well known among CAD/CAM users from machinery and furniture industry, among educational institutions for providing education knowledge and skills of e-learning and web based courses both in Slovakia and Czech Republic. The experienced sale and engineering teams provide the support all our customers needs. Role of the CAD-Up International in the project: participation on TSCC meetings, preparation and design project ICT, research and analysis, quality, evaluation, validation, dissemination, exploitation [4].*

---

#### **■ MAIN TASKS OF THE IRMA PROJECT**

---

*The IRMA project consists in the realization of a Research/Comparative Analysis in the 27 European Union's Member States. The objective of the IRMA is the promotion of excellence, efficiency and fairness of the instruction in Higher Education Institutes, or in other words of access and students' retention in Higher Education. In our opinion excellence refers to the quality and to the level (or capacity) of innovation of the Higher Education's teaching system (contents, methods, technologies used, services provided to students, etc.), efficiency is due to the correspondence among skills and competences provided by Universities and those required by Enterprises and equity can be evaluated thanks to the Equal Opportunities given to students independently from social, cultural, religious and economical factors.*

*The Research is circumscribed to a specific field, the Manufacturing Engineering and is realized involving three Interfaces: Universities, Enterprises and "Intermediary" Institutions (Enterprises Incubators, Technological Poles, Academic Spin-off, Institutional Agencies), with the purpose to understand which are competences and knowledge demanded from Enterprises, which are competences and knowledge supplied from Universities and the competences and knowledge spreaded from Intermediaries [7].*

The project wants to support the introduction of reforms in the educational and training system and to improve the investments in the human capital of Universities, that is to say Students, giving them new instruments and knowledge coherent with the competences demanded from the economy of knowledge, focusing on the state of the art of the way of teaching Manufacturing Engineering in the European Universities.

The goal of Inter-countries Research for Manufacturing Advancement (IRMA) project is, through the research of manufacturing advancement education analysis, to analyze, accelerate and enhance the ability of the education sector to capitalise on the emergence of a powerful information infrastructure on manufacturing advancement. The key components of projects approach are:

- 1.] through selected indicators to conduct the research on current status in education, research and training on manufacturing technologies,
- 2.] research the manufacturing engineering advancement education based on multilateral approach,
- 3.] use of web- based multi language platform to highlight the progress and results increasing the visibility of the research,
- 4.] manufacturing operation scheduling derived from the operation specifications.

Proposed research goals and methods can certainly be used to encourage education facilities and personnel to further explore topics on their own and take ownership of their learning and improve the overall procedures, goals and system of education. Also to encourage the sharing of information, knowledge, to secure the distribution of the top of the line data on manufacturing advancement education through the network.

For instance, the excellence of Universities and their capacity to advance the manufacturing technologies education could be analyzed/evaluated through the following topics of education conducted at the education facilities of interest [8]:

- Creative use of progressive tools for design phases using the modern tools with elements of artificial intelligence as strategic approaches for implementation of modern technologies. It will include the SW technologies (CAD/CAM/CAE/PDM/PLM),

optimization of product design focused on price and manufacturing costs, cooperation and out-sourcing on product design, modern CAPP systems and their implementation.

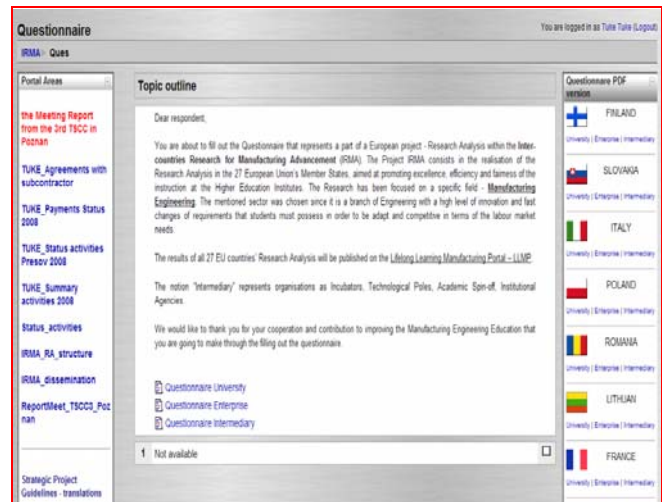

Fig. 1 The Lifelong Learning Manufacturing Portal - LLMP ([www.irmaproject.eu](http://www.irmaproject.eu))

- Use of sophisticated approaches during the production phases focused on new methods in organization and management of manufacturing processes, ERP, MRP systems, logistics, innovation of manufacturing tools, visualization of manufacturing management.
- Implementation of out-sourcing methods of manufacturing processes management. Out-sourcing decision making processes. Implementation phases of out-sourcing management.
- Environmental impacts of cutting edge manufacturing technologies. Environmental approaches of waste management.
- Nanotechnology in manufacturing processes. Development, testing and implementation of nanotechnology use in modern manufacturing processes focused on improvement of manufacturing process effectiveness. Environmental impact and risks of nanotechnology use in manufacturing.

All the data are collected through a web questionnaire, specific for every of the three interfaces, and put in a data base created on the Lifelong Learning Manufacturing Portal (LLMP), that are used as technological instrument to support the research.

The web-based platform is also enable best solutions for communications such as notices, updates, asynchronous and synchronous

discussion, and for content that is frequently updated or only becomes available during the actual project duration. Web based platform allows the direct connection between partners conducting the research on modern information on manufacturing advancement education directly, covering the whole network of partner and non-partner countries [6].

The manufacturing advancement education research is concentrated on analysis, processing, comparative analysis and distribution of the results up to the education personnel, decision makers and stakeholders. Project life-time is underlined by the necessity of conducting research, analysis of current status of manufacturing technologies education, interviews, distribution and analysis of the questionnaires and automatic data collection. The creation of database is executed continuously and should be finished until February 2009. Duration of the project is also dictated by the requirements of impact evaluation and analysis due to the certain period of time to judge the outcome of the research results implementation into the practice.

#### ■ CONCLUSION

Inter-countries Research for Manufacturing Advancement will bring long-term advantages to manufacturing technologies education personnel and decision makers especially in high-quality learning content and applications which allow quick and profitable transfer of research results to the practice. It will improve quality of manufacturing technologies education system and its adaptability to the quickly changing requirements of the manufacturing industry in broad area of knowledge and skills. Life time learning provides the advantage of skills improvement and enhancement which will certainly impact the abilities education systems to better fulfil the assigned tasks. Manufacturing companies are globalizing and expanding worldwide and are outsourcing functions and activities with different requirements. Therefore education of manufacturing technologies is important in this context.

The discipline of Manufacturing Engineering is evolving rapidly to meet the needs of manufacturing industries. It is important for the

development of the discipline to define a common basis for communication and to strengthen networks among educators. This is the only way we can fully realize the benefits of the diversity in the discipline that exist nationally and internationally. The IRMA Project is an opportunity for manufacturing educators to address issues related to global shifts in manufacturing, shifts in jobs, pollution, international trade, and international manufacturing.

#### ■ ACKNOWLEDGMENT

EACEA Brussels supported this work, LLP project No. 2007-1990 "Inter-countries Research for Manufacturing Advancements".

#### ■ REFERENCES

- [1.] BIOLGHINI, D. - MARCINCIN, J. N.: Research Outputs of Lifelong Learning Project on Inter-countries Research for Manufacturing Advancement. *Manufacturing Engineering and Technology*, No. 2, TU Varna (Bulgaria), 2009, pp. 3-5, ISSN 1312-0859.
- [2.] Collective: *Inter-countries Research for Manufacturing Advancements. Project of Lifelong Learning Programme* (www.irmaproject.eu), 2009.
- [3.] COTETIU, R. - MARCINCIN, J. N. - Ungureanu, N. - Cotetiu, A.: LLP Project IRMA in Area of Manufacturing Engineering. *Scientific Bulletin. International Multidisciplinary Conference*, Vol. 23, Serie C, Baia Mare (Romania), 2009, pp. 87-94, ISSN 1224-3264.
- [4.] KALPAKJIAN, S. - SCHMID, S. R.: *Manufacturing Engineering and Technology*. Prentice-Hall, New Jersey, 1148 p., 2001.
- [5.] MARCINCIN, J. N.: Introductory coordinational meeting of partners in international project IRMA. *Hafo TU*, Vol. 16, No. 3, pp. 7, 2008.
- [6.] MARCINCIN, J. N.: Project divided to two phases. *Prešovský večerník*, Vol. 19, No. 23, pp. 12, 2008.
- [7.] MARCINCIN, J. N.: LLP Project IRMA – InterCountries Research for Manufacturing Advancement. In: *Proceedings of 10th International Scientific Conference „Automation in Production Planning and*

*Manufacturing”, SjF ZU Zilina, Turcianske Teplice, 2009, pp. 177-180, ISBN 978-80-554-0008-2.*

[8.] *MARCINCIN, J. N. - ROSSO, C.: InterCountries Research for Manufacturing Advancement. Manufacturing Engineering, Vol. 8, Nr. 3, 2009, pp. 80-83, ISSN 1335-7972.*

[9.] *MARCINCIN, J. N. - ROSSO, C.: Outputs of LLP Project IRMA in Area of Manufacturing Engineering. In: Proceedings of the 13<sup>th</sup> International Conference Trends in the Development of Machinery and Associated Technology TMT 2008. Hammamet (Tunisia), 2009.*

[10.] *ROSSO C., MARCINCIN, J. N.: Inter-countries Research for Manufacturing Advancements. Proposal of Lifelong Learning Programme Project, No. 2007-1990, pp. 01–39, Prešov - Torino, 2007*

---

■ **AUTHORS & AFFILIATION**

---

<sup>1</sup> *DAVIDE BIOLGHINI,*

<sup>2</sup> *JOZEF NOVÁK-MARCINČIN,*

<sup>3</sup> *ROBERT ČEP*

<sup>1</sup> *STUDIO TEOS S.R.L, MILANO, ITALY*

<sup>2</sup> *DEPARTMENT OF MANUFACTURING TECHNOLOGIES, TECHNICAL UNIVERSITY OF KOŠICE, SLOVAKIA*

<sup>3</sup> *DEPARTMENT OF MACHINING AND ASSEMBLY, VŠB - TECHNICAL UNIVERSITY OF OSTRAVA, CZECH REPUBLIC*



---

## ***SYSTEMS TO OPTIMIZE COMFORT AND DEVELOPMENTS OF CAR SEAT***

---

---

### ■ **Abstract:**

*Optimizing comfort of car seats is currently of great importance. Trend in the development and construction of seats shows that not only the safety of passengers, but also mainly on the comfortable cushion layer strong emphasis. Thus recent developments seats is based on systems and optimizing comfort. Mechanical properties of materials, from which car seat is made, therefore, play a major role in the overall assessment of comfort. Comfort layer of rules includes PU materials, fabric and wire. Mechanical properties of PU material, fabric shall be measured experimentally on test equipment. Obtained experimental data are the basis for virtual simulation in FEM. To optimize comfort is important to examine the contact pressure, which can be used to find comfort criteria for comparing the seats.*

---

### ■ **Keywords:**

*car seat, Comfort, constact pressure, MKP*

---

---

### ■ **INTRODUCTION**

*Quality and safety of seating on the automobile seat depends mainly on material characteristics of the comfort layer. Human body is in permanent contact with the seat. Optimalization of the comfort layer is very significant for seat producers. Viscous-elastic behavior of the polyurethane foam (PU foams) is very important for the development and optimization of automotive seating comfort. Getting results is very time-consuming and financially demanding, because it is the experiments on humans. The main aim of this letter is describe optimizing of the comfort layer by using finite element simulations. FEM is significant, because the system helps in optimizing comfort. Virtual testing makes possible to modify properties of foam cushion to analyze and optimize pressure*

*distribution. Analyses allow investigations of parameters that are hard to measure. It is possible to use common polyurethane materials or sandwich structure which have get better contact pressure distribution. There is possible to optimize static comfort during the seat development (predicting the whole seat behavior). Comparing results test, collect results to optimize seat. The covering material is on all types of seats pre-stressed and it is very significant to static comfort. Differences between pressure peaks on the covered and uncovered seats are between 30 – 60% (experience from real testing [3], [6]).*

*By using FEM simulation are producers of automobile seats able to save time and money during the seat development. We want to build for the future data of the mechanical properties*

through experimental measurement and evaluation of the data for comfort seats to the virtual simulation. Then we will be able compare different automobile seats in real tests and make virtual simulations.

**METHODOLOGY OF SIMULATION TESTS**  
**Experimental measure**

Virtual Simulations are built based on experimental data measured in specialized test equipment. Mechanical properties of upholstery fabrics from the tensile test are obtained from the test facility (fig. 1).



Fig.1 Experimental tests of Cover-Textil fabric



Fig.2 Tests car seat from PU foam

Mechanical properties PU foam were measured on the standard sample (standard Cube of dimensions 100x100x50) [3], [7], [8] and particular by experimental tests for to testing car seat facilities (fig.2).

**Simulation tests**

Simulation models were created in an environment of FEM. The model was made of PU material, from a sandwich material. Models

were tested from Cover-Textile Fabric and without the Cover-Textile Fabric.

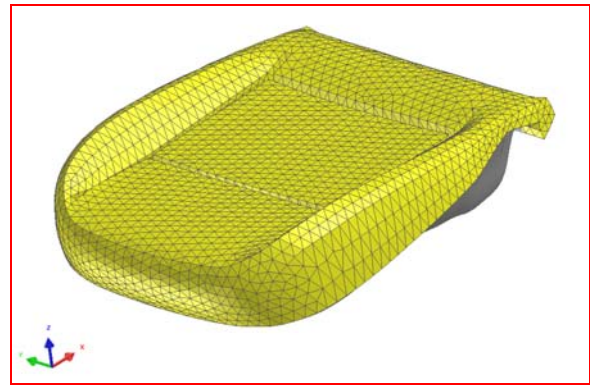

Fig. 3 Model uncovered seat

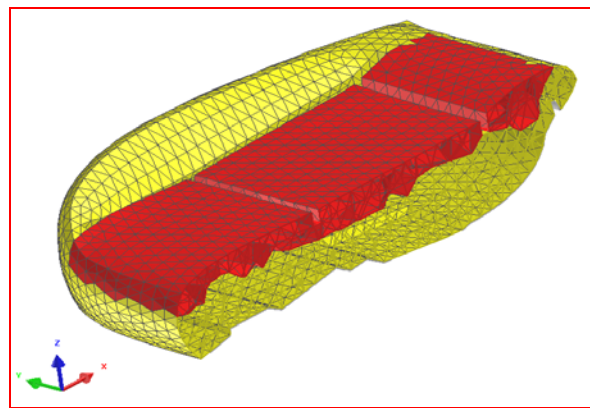

Fig. 4 Model sandwich seat

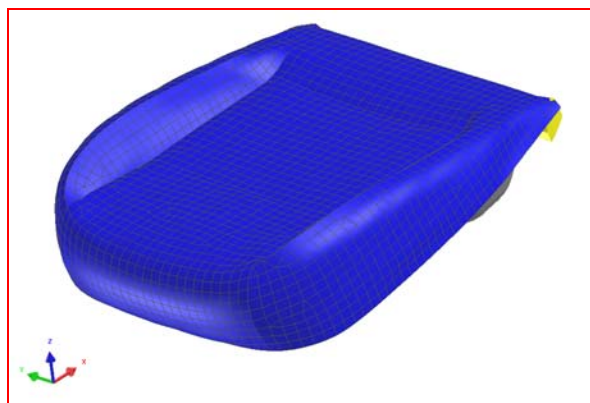

Fig. 5 Model covered seat

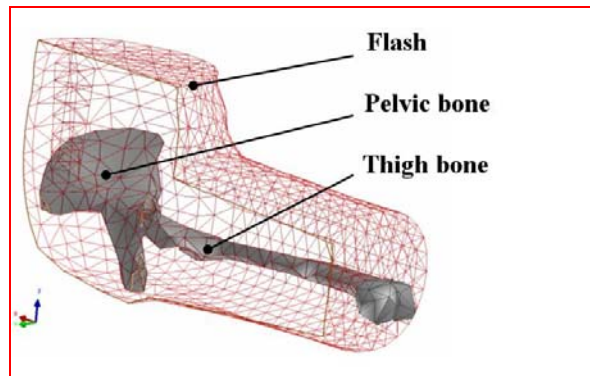

Fig. 6 Virtual human body



Both sandwich seats contain two different types of polyurethane foam. The main part of the foam is common material used in standard seats and the soft foam in the contact area.

The virtual human body model contains parts of skeleton like pelvic bone and thigh bone (Fig.6). This part of skeleton is fleshed by human body tissue. Characteristics of the tissue are optimized from the letters [2], [3] and [4].

Tab. 1 Characteristics of the human body model

Part	Material model	Density $\rho$ [kg/m <sup>3</sup> ]	Young's modulus E [GPa]	Poisson number $\mu$ [-]
thigh bone	Elastic Plastic	1000	0.250	0.3
pelvic bone	Elastic Plastic	1000	0.250	0.3
flesh	Elastic	1200	8.E-5	0.4

The lower plate is fixed in all degrees of freedom. The mass of the human body model is 61 kg. Initial position of the human body is optimized to get no penetration with seat. There is defined gravity acceleration field on the whole human body. The result analysis is done after equilibrium of the human body on the seat.

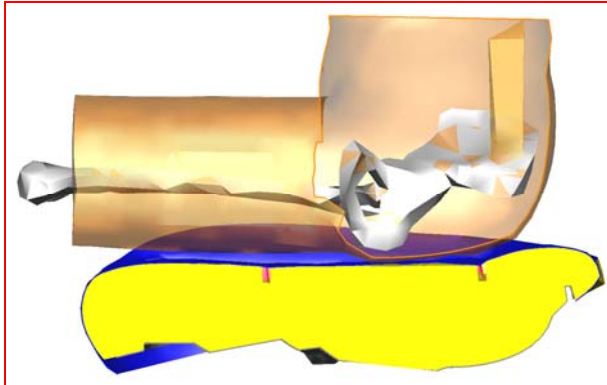

Fig. 7 Initial position

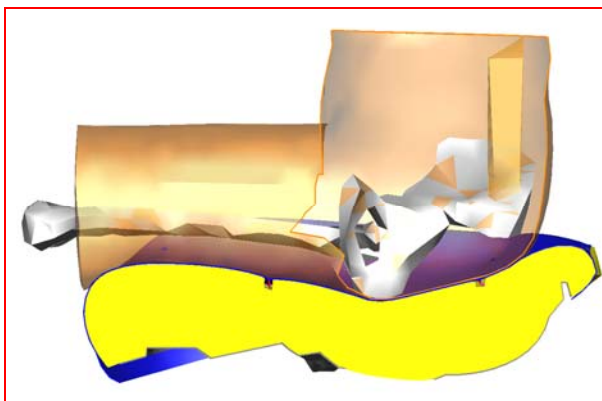

Fig.8 Result position

Material characteristics virtual models

Virtual simulations are made in PAM COMFORT from ESI GROUP. Solver of PAM COMFORT is based on PAM CRASH explicit integration scheme and is optimized for comfort static and dynamic simulations. Explicit method (Explicit Solver) and the mathematical relationships were referred to in Article [7], [8].

PU Foam characteristics are included as static stress-strain curves (Fig. 9). Measure and simulation described in detail in Article [3], [7]. Static characteristics are analyzed by using special methodology to describe creep and stress relaxation. Textile fabric characteristics in directions loading are included as stress-strain curves (Fig.10). As the material properties are given further variables such as density, Young's modulus, viscoelastic coefficients, stiffness damping, coefficient, absorption Energy and other factors.

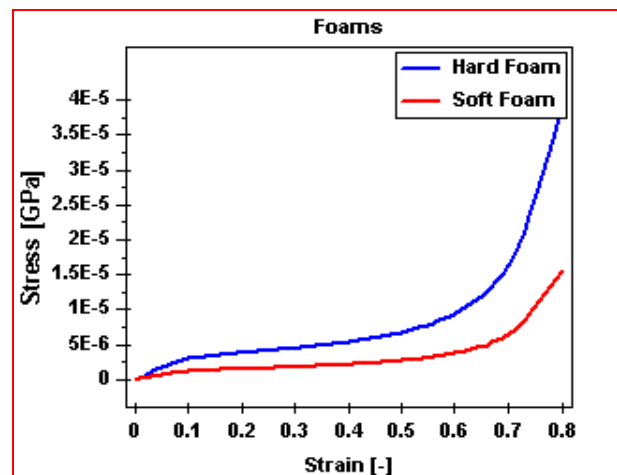

Fig. 9 Covered seat

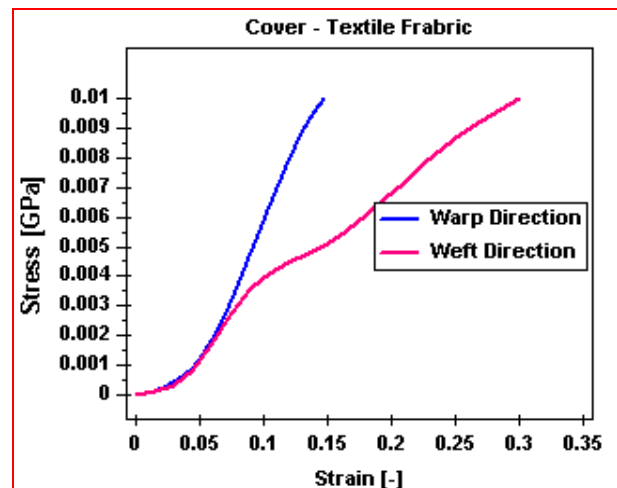

Fig. 10 Uncovered seat

**RESULTS OF THE SIMULATIONS**

Simulation analysis uses contact pressure to compare different types of seats (Compare comfort, optimization design, construction geometry, developments ...).

Differences between maximum contact pressure seat (PU foam) and sandwich seat is c. 14%. This is due to layering of the material. Contact peak pressure by using sandwich seat is lower. Soft foam in contact area increases contact area and the static comfort. There is high dependency of the covering material. Increment of the peak pressure values is c. 62%. The covering material has important influence to seat stiffness and to static comfort. Therefore it can be assumed that values of contact pressures obtained from simulation model are suitable and can be used for the evaluation of these materials and seats.

The Fig. 11 and 12 is seen compression virtual Human body for uncovered seat and seat Sandwich. The resulting values maximal contact pressures for compared uncovered seat and seat Sandwich in Table 2.

Tab. 2 Results – Contact Pressure

Virtual Seat	Maximum of Contact Pressure [GPa]
Uncovered	1.15E-5
Uncovered Sandwich	1.01E-5
Covered	1.87E-5
Covered Sandwich	1.73E-5

All Results simulation for optimize and compares contact map (contact zone) seats with human body which is performed using contact pressure are to fig. 13-16.

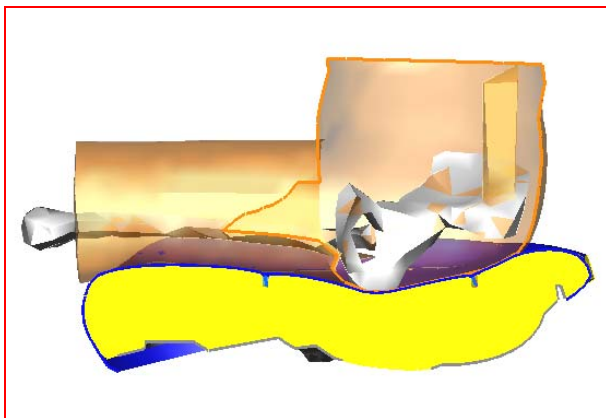

Fig. 11 Compression seat (uncovered seat)

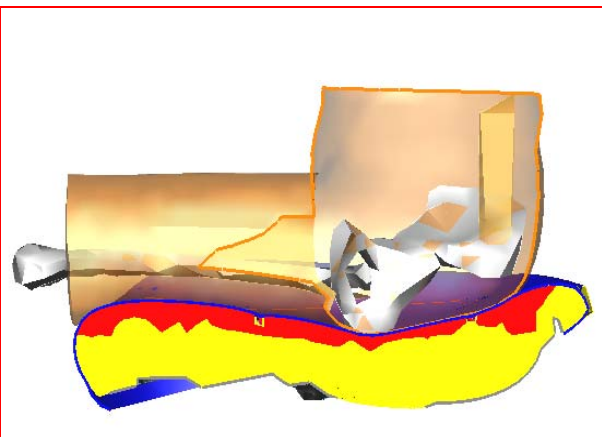

Fig. 12 Compression seat (Sandwich seat)

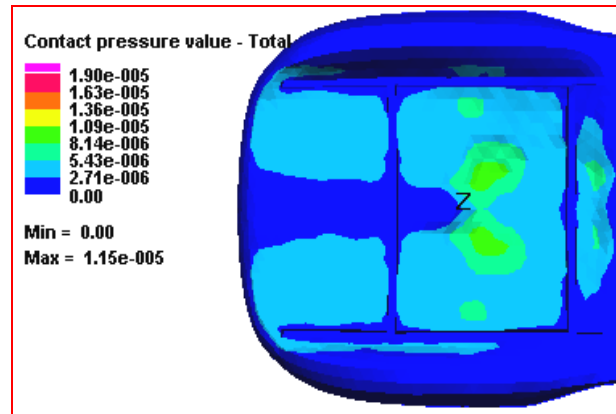

Fig. 13 Uncovered seat

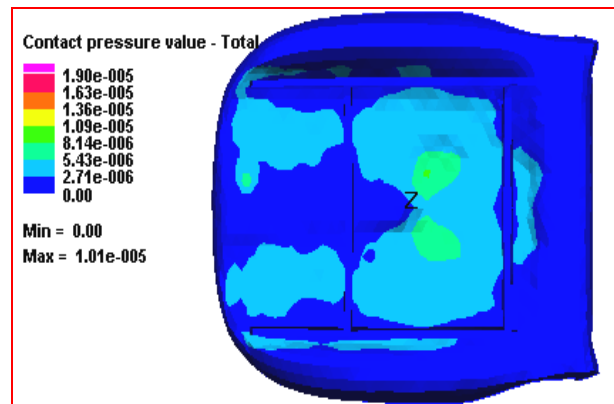

Fig. 14 Uncovered sandwich seat

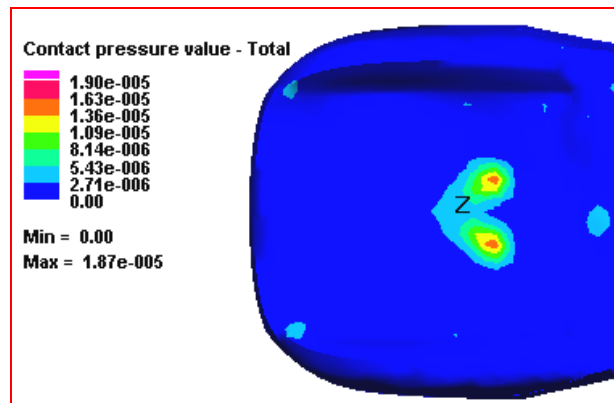

Fig. 15 Covered seat

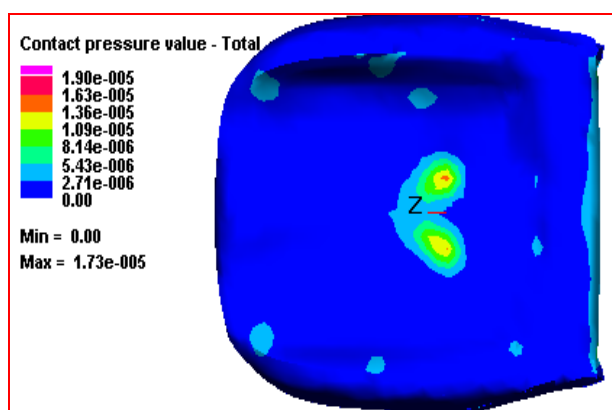

Fig. 16 Covered seat

## CONCLUSION

An evaluation properties of seats, especially a pressure distribution in the contact zone, during the interaction between the sample and load is very important for the comfort. It is possible to use FEM simulations to predict comfort analysis. It is necessary to use the same testing signal in real experiment and in simulations. It is possible to predict dynamic behavior of the automotive seats before the prototype is made and optimizing mechanical characteristics of used materials and optimizing comfort layer of the seat cushion. By using FE model is possible to compare comfort layers with different shapes of seat cushion. During the seat development is important to include covering material influence to static comfort analysis. The sandwich structure is useful to get lower peak of contact pressure and increases the static comfort. FEM simulations will be very helpful to optimize characteristics of the comfort layer. It is possible to use different types of foam, covering materials, levels of pre-stress of textile fabric without the real seat prototype. Also It exists special device for measurement of contact pressures, for example X-sensor, which is very suitable for comparison with the virtual simulation, but its price is very high. FEM Simulations as important system for Optimization for Comfort and Development.

## ACKNOWLEDGMENT

This paper arises by the subvention research project of Ministry of Education of the Czech Republic under contract code MSM 4674788501.

## REFERENCES

- [1.] PETŘÍK, J., PETRŮ, M.: Optimization of the seat cushion comfort layer In: 50. Conference of Departments of Parts and Mechanism of Machines, 8<sup>th</sup> - 10<sup>th</sup> September 2009, Terchová, SK, ISBN 978-80-554-0080-8
- [2.] JAY (ZHUIJIAN) ZHAO, GOPAL NARWANI, Development of a human body finite element model for restraint system r&d applications takata – Automotive Systems Laboratory, Inc. Paper Number 05-0399
- [3.] PETRIK JAN, FE model of the foam cushion, PHD 2007, Pilsen
- [4.] KENT, R., SHERWOOD, C., LESSLEY, D., OVERBY, B., MATSUOKA, F., "Age-Related Changes In The Effective Stiffness of The Human Thorax Using Four Loading Conditions." in Proceedings of RCOBI Conference, 2003.
- [5.] MLIT/JAMA/JARI, "Proposals for Activities on International Harmonization Advanced Frontal Impact Dummies." IHRA BIO-WG in Washington D.C., USA, July 16, 2004.
- [6.] PETRIK JAN, Iteration of the automobile seat and weight, Doctoral Thesis, TU Liberec, 2008
- [7.] PETŘÍK, J., PETRŮ, M.: Simulation of the transmissibility of the non-linear materials In: VIBROENGINEERING 2009, Proceedings of the 8<sup>th</sup> International Conference, Klaipeda, Lietuva, ISSN 1822-1622
- [8.] NOVÁK, O., PETRŮ, M.: Simulation Of Mattresses For Immobile Patients In: AUTEX 2009 World Textile Conferencion, Izmir, Turkey, ISBN 978-975-483-787-2

## AUTHORS & AFFILIATION

<sup>1</sup>MICHAL PETRŮ,

<sup>2</sup>JAN PETŘÍK

<sup>1,2</sup>DEPARTMENT OF MACHINE ELEMENTS AND MECHANISM, TECHNICAL UNIVERSITY OF LIBEREC, CZECH REPUBLIC

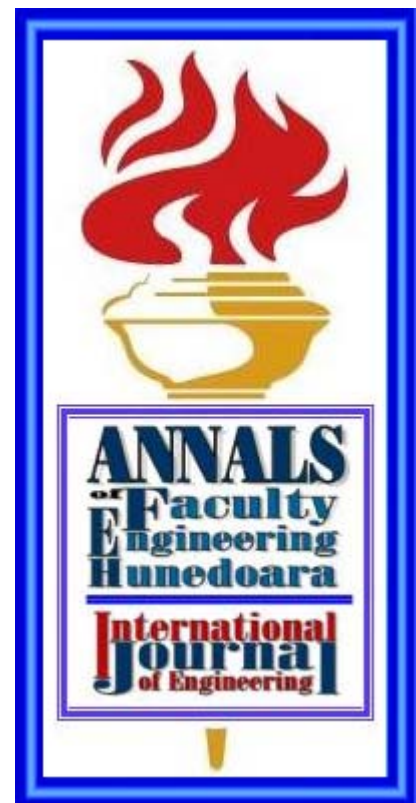

---

***ANNALS of FACULTY ENGINEERING HUNEDOARA  
– JOURNAL of ENGINEERING”***



*since 2003*

---

■ **DEAR COLLEAGUES,**

*“ANNALS OF FACULTY ENGINEERING HUNEDOARA – JOURNAL of ENGINEERING” is an international and interdisciplinary journal which reports on scientific and technical contributions.*

*Scientists and engineers with an interest in the respective interfaces of engineering fields, technology and materials, information processes, research in various industrial applications are invited to publish in our journal. “ANNALS OF FACULTY ENGINEERING HUNEDOARA – JOURNAL of ENGINEERING” publishes articles of interest to researchers and engineers and to other scientists involved with materials phenomena and computational modeling.*

■ **ABOUT THE “ANNALS OF FACULTY ENGINEERING HUNEDOARA – JOURNAL of ENGINEERING”**

*The “ANNALS OF FACULTY ENGINEERING HUNEDOARA – JOURNAL of ENGINEERING” (ISSN 1584 – 2665, for printed version, ISSN 1584 – 2673, for electronic format) has been published since 2003, in English, replacing the “ANNALS OF FACULTY ENGINEERING HUNEDOARA – JOURNAL of ENGINEERING” (ISSN 1454 – 6531), that appeared regularly since 1999, in Romanian. The “ANNALS OF FACULTY ENGINEERING HUNEDOARA – JOURNAL of ENGINEERING” has been issued on a regular basis since 2003, twice a year in printed form (FASCICULE 1 and FASCICULE 2) and once a year in electronic format (FASCICULE 3). We mention that our intention is to include the “ANNALS OF FACULTY ENGINEERING HUNEDOARA – JOURNAL of ENGINEERING” in the international databases, and this is the main reason we are trying to advertise it in ROMANIA and abroad. In the name of the FACULTY OF ENGINEERING HUNEDOARA, the entire professor’s collective, and, of course, in my personal name, we thank you for the attention. We are looking forward to a fruitful collaboration and we welcome you to publish in our “ANNALS OF FACULTY ENGINEERING HUNEDOARA – JOURNAL of ENGINEERING”. This JOURNAL is a good opportunity for the researchers to exchange information and to present the results of their research activity. We hope that it will be possible to initiate future research themes and projects in the frame of bilateral or multilateral basis, including participation in EUROPEAN UNION programs.*

Every year, in three issues, "ANNALS OF FACULTY ENGINEERING HUNEDOARA – JOURNAL of ENGINEERING" publishes a series of reviews covering the most exciting and developing areas of engineering. The result is a journal that gives the scientists and engineers the opportunity to keep informed of all the current developments in their own, and related, areas of research, ensuring the new ideas across an increasingly the interdisciplinary field.

"ANNALS OF FACULTY ENGINEERING HUNEDOARA – JOURNAL of ENGINEERING" encourages the submission of comments on papers published particularly in our journal. The journal publishes articles focused on topics of current interest within the scope of the journal and coordinated by invited guest editors. Interested authors are invited to contact one of the Editors for further details.

---

#### ■ **ABOUT THE FACULTY OF ENGINEERING HUNEDOARA**

---

The INSTITUTE OF TECHNOLOGICAL ENGINEERING OF HUNEDOARA was founded in 1970, pursuant of the Decision of the Council of Ministers. 1271/1970. In the beginning, this institute functioned with day and evening courses in two profiles: Metallurgy, with special training in Blast Furnaces and Steelworks and Thermal Deformations and Treatments, respectively Electromechanics, with special training in Technological Electromechanics. Along the years, we also had special training in Carbon-chemical Technologies and Civil, Industrial and Agricultural Constructions in the profile Constructions. Students used to be trained in day courses (3 years) and evening courses (4 years). Until 1974, The INSTITUTE OF TECHNOLOGICAL ENGINEERING OF HUNEDOARA was subordinated to the Mining Institute of Petroșani.

Starting university year 1974 – 1975, once the network of Institutes and Faculties belonging to the Ministry of Education and Schooling was approved through the Decree of the State Council no. 147/1974, The INSTITUTE OF TECHNOLOGICAL ENGINEERING OF HUNEDOARA was subordinated to the POLYTECHNIC INSTITUTE "TRAIAN VUIA" OF TIMIȘOARA.

The DEPARTMENT OF METALLURGY appeared in 1974, and was originally the DEPARTMENT OF TECHNOLOGY, created in 1971 one year after the INSTITUTE OF HIGHER EDUCATION was founded. The department ensures the education of the students of the FACULTY OF ENGINEERING OF HUNEDOARA in the field of metallurgical processes, plastic working and thermal treatments, ferrous and non-ferrous alloy casting, metallurgical equipment and aggregates, economical engineering in the field of mechanics, the chemical and material industry. The department coordinates the education in the fields of Engineering of Metallurgical Processes (Plastic Working and Thermal Treatments, Metal Casting), Economical Engineering in the Chemical and Material Industry and the Optimization of Metallurgical Processes and Master, being in charge with the drawing up of the curricula and the coordination of the professional instruction in these fields. Starting university year 1985 – 1986, the DEPARTMENT OF CASTING was added to the already existent profiles.

The FACULTY OF ENGINEERING OF HUNEDOARA started its activity in university year 1990 – 1991, when the INSTITUTE OF TECHNOLOGICAL ENGINEERING was restructured by Order of the Ministry of Education no. 7751/1990, which approved of the long term (5 years) higher education courses at the FACULTY OF ENGINEERING OF HUNEDOARA. The evening courses for technological engineers were maintained in parallel with the engineering day courses until all the students that had started studies before 1990 graduated.

The DEPARTMENT OF MECHANICS was founded in 1995, by splitting the DEPARTMENT OF ELECTRO-MECHANICS. The teaching staff of the department covers both the fundamental objects (Linear Algebra, Analytical and Differential Geometry, Mathematical Analysis, Special Mathematics, Numerical Analysis, Physical Education) and the technical objects in the field of study, according to the respective curricula: Electrical Engineering, Economical Engineering, Industrial Engineering, Mechanical Engineering, The Engineering of Transportation, Applied Sciences, and the Engineering of Materials. The DEPARTMENT has been coordinating from its foundation the specialization in "Equipment for Hot Processing" then, since university year 2001-2002, the specialization in "Economical Engineering in the Field of Mechanics" and finally, since university year 2003-2004, the specialization in "Automotive Vehicles", being particularly interested in the contents of the curricula and the corresponding analytical programs, as well as in the carrying out of the didactical and

*practical activities. For university year 2004-2005 we made the proper diligences meant to found and start the activity of a new post-university - Master course: "Advanced Methods and Means of Designing Mechanical Systems".*

*The DEPARTMENT OF ELECTROTECHNICS functions within the FACULTY OF ENGINEERING OF HUNEDOARA since 1995 as a result of the splitting of the Department of Electromechanics, namely: the teaching staff specialized in electricity, which at present constitutes most of the DEPARTMENT OF ELECTROTECHNICS and the teaching staff specialized in mechanics, belonging now to the DEPARTMENT OF MECHANICS. Within the DEPARTMENT OF ELECTROTECHNICS, besides the teachers specialized in electricity, also work the teachers of foreign languages, English and French and also the titular of the subject Physics. Until 2001 to this department also belonged the teaching staff of economic subjects, at present belonging to the DEPARTMENT OF METALLURGY. This department is also in charge with the TECHNICAL UNIVERSITY COLLEGE, which offers the following specializations: Technical Computer Science, Electronics, IT and Applied Electronics.*

*Starting university year 1993 – 1994, The TECHNICAL UNIVERSITY COLLEGE was founded, using the same human and material resources as the FACULTY OF ENGINEERING OF HUNEDOARA. Didactically and administratively, the TECHNICAL UNIVERSITY COLLEGE is subordinated to the FACULTY OF ENGINEERING. University year 2000 – 2001 meant for the FACULTY OF ENGINEERING OF HUNEDOARA the opening of the DEPARTMENT FOR LIFE LONG EDUCATION whose target is post-university professional reconversion of higher education graduates.*

*The research activity of the teaching staff is recognized by the NATIONAL COUNCIL OF SCIENTIFIC RESEARCH IN HIGHER EDUCATION INSTITUTIONS, which approved of the opening within the FACULTY OF ENGINEERING OF HUNEDOARA of a RESEARCH CENTER on "OPTIMIZATIONS IN THE INDUSTRY OF MATERIALS". The CENTER is involved in activities of material obtaining, automation, computer-controlled processes in material industry, endurance and safety in exploitation of materials. Since the founding of the higher education institution in HUNEDOARA, the research activity, alongside with the didactical one have been carried out starting from the needs of the industrial zone and the needs of self endowment of the departments. The DEPARTMENT OF ELECTRO-TECHNIQUES is endowed with laboratories specialized in the functioning of electric rotary machines and transformers, electric installations, electric and electronic circuits, data acquisition and processing systems, the analysis of the quality of electric energy for several consumers, the study of electromagnetic compatibility, the analysis and synthesis of automatic regulation systems for industrial processes using both classical regulation methods and methods based on the fuzzy logic, neuronal networks and experts systems.*

*In the laboratories of the DEPARTMENT OF METALLURGY research can be made in the field of chemistry, plastic deformations, studies related to the elaboration of ferrous and non-ferrous materials and thermal treatments.*

*The material resources and the infrastructure of the DEPARTMENT OF MECHANICS offer the possibility to perform mechanical trials at room and low temperatures, researches on the behavior of some machine parts in function (belts, bearings, springs, etc.) and the tribological analysis of the lubricants and various pairs of materials.*

*The buildings where the FACULTY OF ENGINEERING OF HUNEDOARA carries out its activity are all next to one another and they are: four buildings meant for didactical activities, one administrative building, two buildings meant for production and maintenance. Besides, the Faculty has one hostel with 38 rooms, 114 places and a canteen. Between 1973 – 1974, The IRON AND STEEL INTEGRATED PLANT OF HUNEDOARA donated the necessary funds for constructing three-storey building B, and the technological shed, having a total area of 1100 sq.m. Between 1977 – 1978, using funds offered by the Ministry of Education, we constructed in the same area three-storey building C, having a surface of 990 sq.m. and a gym hall with a surface of 600 sq.m. In the six amphitheatres, one auditorium, fourteen seminar rooms, one gym hall and thirty laboratories, we can grant the teaching process, five days a week, 4-8 hours a day. The FACULTY OF ENGINEERING OF HUNEDOARA has a library with a surface of 262 sq.m., and the book depot, with a surface of 130 sq.m. has over 95,000 volumes in store, respectively more than 42,000 titles.*

*Starting 1999, our Faculty has been organizing sessions of scientific communications to which participate teaching staff and researchers from numerous countries. The scientific papers presented*

on these occasions are published in the "ANNALS OF FACULTY ENGINEERING HUNEDOARA – JOURNAL of ENGINEERING", ISSN 1454 – 6531. The results of the research activities that are made public on these occasions lead to an increase of the prestige which the FACULTY OF ENGINEERING OF HUNEDOARA enjoys. The DEPARTMENT OF LIFE LONG EDUCATION of the FACULTY OF ENGINEERING OF HUNEDOARA was founded in the spring of 2000 as a result of the need to create a center in this area, capable of offering the possibility of initial or continuous professional formation, or for the re-conversion of the workforce laid off, to top fields of activity or domains that offer a sure perspective in the near future.

---

■ **INVITATION**

---

Now, when you know us, in this way, you are invited to present your activity covering the full spectrum of engineering. "ANNALS OF FACULTY ENGINEERING HUNEDOARA – JOURNAL of ENGINEERING" is an international and interdisciplinary journal which reports on scientific and technical contributions. Thank you in advance for selecting us.

*THE EDITORIAL BOARD*

**ANNALS of FACULTY ENGINEERING HUNEDOARA  
– INTERNATIONAL JOURNAL of ENGINEERING**

**ISSN: 1584-2665 [print]**

**ISSN: 1584-2673 [CD-Rom]**

**copyright © UNIVERSITY POLITEHNICA TIMISOARA**

**FACULTY OF ENGINEERING HUNEDOARA**

**5, REVOLUTIEI**

**331128 – HUNEDOARA**

**ROMANIA**

**<http://annals.fih.upt.ro>**



**ANNALS  
of Faculty  
Engineering  
Hunedoara**  
**International  
Journal  
of Engineering**



---

**VII<sup>th</sup> INTERNATIONAL CONGRESS  
"MACHINERY, TECHNOLOGY, MATERIALS"  
– INNOVATIONS FOR THE INDUSTRY**



**26. – 28.05.2010  
SOFIA, BULGARIA**

---

---

■ **INVITATION**

*The SEVENTH INTERNATIONAL CONGRESS "MACHINERY, TECHNOLOGY, MATERIALS'10" will be carried out together with the EXHIBITION OF MECHANICAL ENGINEERING MECHTECH'10 in Inter Expo Center Sofia.*

*Together and collaborating these two events will form the industrial forum "MACHINERY, TECHNOLOGY, MATERIALS – INNOVATIONS FOR THE INDUSTRY". We hope that in this way the Congress will become a bigger innovation mediator between scientific research and industry.*

*The program of the Congress offers you different ways to present the results of your research in front of you colleagues and the representatives of the industry. We invite you to take advantage of these opportunities.*

*Beside the international congress **MTM'10** and MECHTECH'10 the INDUSTRIAL FORUM includes: EXHIBITION MECHTECH in the halls of INTER EXPO & CONGRESS CENTER OF SOFIA and Innovations exchange and consulting services for the Industry.*

*We invite you to take part (personally or by correspondence) in the VII INTERNATIONAL CONGRESS **MTM'10** with publishing of your papers or messages on innovative technical solutions for the industry. You are welcome to participate either in the common stand "SCIENTIFIC INNOVATIONS FOR THE INDUSTRY" which is organized by us.*

---

■ **TOPICS:**

01. MACHINES
02. TECHNOLOGIES
03. MATERIALS

---

■ **SCIENTIFIC PROGRAM:**

---

- ✚ *PLENARY SESSION with ordered papers*
  - ✚ *SECTIONAL SESSIONS in the congress halls of Inter Expo & Congress center*
  - ✚ *POSTER PRESENTATIONS OF PAPERS at the congress stand in the exposition of the Forum*
  - ✚ *Participation with models, prospects, samples and/or multimedia presentations at the “SCIENTIFIC INNOVATIONS FOR THE INDUSTRY stand in the Forum’s exposition.*
- OFFICIAL LANGUAGES AT **MTM’10**: BULGARIAN, RUSSIAN, ENGLISH*
- 

■ **PUBLICATIONS:**

---

- ✚ *In separate volume ISSN 1310-3946 of the proceedings for each topic session, which will be lodged in St.St. Cyril and Methodius National Library and Central Scientific-technical Library in Bulgaria*
  - ✚ *In CD, containing all papers.*
  - ✚ *Detached issue of the International virtual scientific-technical journal “MACHINERY, TECHNOLOGY MATERIALS” (ISSN 1313-0226). This publishing is at will and requires additional payment.*
  - ✚ *Author’s scroll, containing the title page, the content of the volume and printed copy of the author’s paper with the page numbers from the Proceedings.*
- 

■ **IMPORTANT DATES:**

---

- ✚ *Sending the full text of the paper and Application Form “A”: 15.02.2010*
  - ✚ *Confirmation of the paper receiving: 01.03.2010*
  - ✚ *Payments and Application Form “B”: 15.03.2010*
  - ✚ *Announcement of the plenary and sectional sessions program on our web page: 15.04.2010*
  - ✚ *The Organizing Committee will receive posters up to: 15.04.2010*
  - ✚ *Receiving of the application for transfer: 14.05.2010*
  - ✚ *Registration of the participants: 25 and 26.05.2010*
  - ✚ *Opening of the congress: 26.05.2010*
- 

■ **TIME AND SPACE:**

---

26 - 28. 05. 2010,  
Inter Expo Centre,  
bul. „Tzarigradsko shose” №147,  
SOFIA – BULGARIA

---

■ **SECRETARIAT:**

---

SCIENTIFIC-TECHNICAL UNION OF MECHANICAL ENGINEERING  
108 RAKOVSKI STR.,  
1000 SOFIA  
TEL./FAX (+359 2) 986 22 40,  
TEL. (+359 2) 987 72 90  
[nts-bg@mech-ing.com](mailto:nts-bg@mech-ing.com) ,  
[www.mech-ing.com/mtm](http://www.mech-ing.com/mtm)  
Skype: NTSMashinostroene



---

**3<sup>RD</sup> INTERNATIONAL CONFERENCE  
FOR ENTREPRENEURSHIP, INNOVATION  
AND REGIONAL DEVELOPMENT  
- ICEIRD 2010**



**THEME:**  
**ENTREPRENEURSHIP BEYOND CRISIS  
- CHANNELLING CHANGES TO ADVANTAGE**  
**NOVI SAD, SERBIA**  
**27 - 29 MAY 2010**

---

■ **ORGANISED BY**

*UNIVERSITY OD NOVI SAD,  
FACULTY OF TECHNICAL SCIENCES,  
DEPARTMENT FOR INDUSTRIAL ENGINEERING AND MANAGEMENT  
UNIVERSITY OD NOVI SAD, UNESCO CHAIR IN ENTREPRENEURIAL STUDIES  
CISCO ENTREPRENEUR INSTITUTE, TRAINING CENTER SERBIA*

---

■ **TARGET AUDIENCE**

*The conference is addressed at national and regional government representatives in all countries of South-East Europe, who are involved in the process of policy making in the area of Innovation, Entrepreneurship and Regional Development. Special target group are enterprises, as well as non-governmental organizations active in conference topics.*

*The conference brings together policy makers, experts, practitioners, professors, business people and scientists in this subject area. ICEIRD 2010 will make a contribution to policy making and new ideas*

on competitiveness in the region. Special target audience are students, young researchers, scientists, and their supervisors from academia and industry to present actual research projects and results.

---

■ **OBJECTIVES AND SCOPE OF THE CONFERENCE**

---

*We live in a time of change, in a fast evolving, increasingly global and competitive economy. Sustaining a competitive advantage requires that individuals, companies, and nations anticipate, stimulate and manage change rather than simply react to it. This is what entrepreneurship is about: channeling change to your advantage. New ideas generate new realities and this requires knowledge from different disciplines and the ability to combine such insight with the daily practical realities of business life.*

*We hope that ICEIRD 2010 will give small contribution how to achieve this delicate balance by itself combining both theory and practice, gathering in the same place decision makers (government, ministries- and state agencies), scientists (universities, research and development centres, start-up centres and incubators) and practitioners (SME's) in order to discuss topic that are of crucial importance for national competitiveness and increased regional development in the South East Europe. The key areas of the conference are:*

- *Entrepreneurship as a process of identifying opportunities and putting useful ideas into practice; Innovation as the driver of national, regional and global economy;*
- *Regional development and the possibilities and barriers for closer cooperation between South East European economies.*

---

■ **MISSION:**

---

*Mission of the International Conference for Entrepreneurship, Innovation and Regional Development (ICEIRD) is to strengthen the entrepreneurial spirit and help develop and sustain economic growth by fostering innovation, through the academic knowledge and expertise. ICEIRD Consortium has been established to provide a multi-disciplinary and cross-sectoral forum for researchers, practitioners, and policy makers in the field of innovation and regional development, and a means for sharing findings that promote innovation and therefore enhance economic, technological and regional socio-economic development through new economic activities that stimulate generation of wealth through entrepreneurial and sustainable employment and growth and thus increase competitiveness as well as civil society development and enhancement via the inter-networking of disciplines, researchers, policy makers and practitioners in diverse countries in the region.*

*The ICEIRD Consortium drives research agenda in the field of technology, innovation and entrepreneurship and regional economic development. It is one of the premium and pioneering consortia that successfully and effectively link theory and practice through well-established research outputs and annual meetings.*

---

■ **TOPICS OF INTEREST**

---

***Creativity, Complexity and Competitiveness Issues for Small and Medium Enterprises (EU and other)***

- ✚ *Leveraging e-skills for Innovation in the Knowledge Society*
- ✚ *Managing and Leveraging Complexity, Creativity and Innovation in SMEs*
- ✚ *Trust, Respect, Culture and Collaboration Issues for SMEs in SEE vs. other regions (EU)*
- ✚ *Leadership and Management practices that can be applied to SMEs*
- ✚ *SME Business process modeling, SME Knowledge management and technology transfer*
- ✚ *New Technology Ventures Financing*
- ✚ *Business incubation management and leadership*
- ✚ *Human Resources Practices for promoting innovation for SMEs*

***South East European Entrepreneurial and Innovation Clusters***

- ✚ *SMEs' Entrepreneurship as an Innovation Driver*

- ✚ *Opportunities and barriers for closer cooperation between South East European SMEs*
- ✚ *Strategic Integration vs. Flexibility and SME Competitiveness*
- ✚ *Innovation Clusters, Technology Transfer and Social Entrepreneurship*
- ✚ *Social Networking as Driver of EICs formation*
- ✚ *Science & Technology Parks and EICs*
- ✚ *Young and Women Entrepreneurs development via EICs*
- ✚ *Benchmarking of Entrepreneurship and Innovation Best Practices in the region*
- ✚ *Innovation policy in SMEs*

**Technology Innovation, Transfer and Commercialization across Government, University,**

- ✚ *The role of the State and Public Policy with regards to SME Innovation and Entrepreneurship*
- ✚ *Governmental and regional policies on entrepreneurship and innovation*
- ✚ *Entrepreneurial Universities and Entrepreneurial Innovation Clusters*
- ✚ *Entrepreneurship education, University – Industry collaboration*
- ✚ *Innovative supply chains, Innovative Supply Chain Management practices in SEE*
- ✚ *SMEs and the role of the Innovation Zone (business centers and incubators)*
- ✚ *Intangibles Valuation and Intellectual Property Rights*

---

**■ IMPORTANT DATES**

*Submission of abstracts: 22nd January 2010*

*Notification of acceptance: 26th February 2010*

*Submission of papers: 26th March 2010*

*Submission of camera ready full papers: 23rd April 2010*

*Early registration and author registration: 23rd April 2010*

---

**■ SCIENTIFIC COMMITTEE – Conference Chair**

*Dr. Zoran Anisic, University of Novi Sad, Novi Sad, Serbia*

---

**■ SCIENTIFIC COMMITTEE – Conference Executives**

*Dr. Ari-Veikko Anttiroiko, University of Tampere, Tampere, Finland*

*Professor Elias Carayannis, George Washington University, Washington DC, USA*

*Professor Ilija Cosic, University of Novi Sad, Novi Sad, Serbia*

*Mrs. Cotet Domnica, Mechanical Research Engineering Institute, Bucharest, Romania*

*Professor Robert Huggins, University of Wales Institute, Cardiff, United Kingdom*

*Professor Panayiotis Ketikidis, City College, Thessaloniki, Greece*

*Professor Nicos Komninou, Urban and Regional Innovation Research Unit, Thessaloniki, Greece*

*Professor Siau Ching Lenny Koh, University of Sheffield, Sheffield, United Kingdom*

*Dr. Zenon Michaelides, University of Liverpool, Liverpool, UK*

*Professor Roumen Nikolov, University of Sofia, Sofia, Bulgaria*

*Professor Leon Oerlemans, Tilburg University, Tilburg, Netherlands*

*Dr. Luke Pittaway, Georgia Southern University, Statesboro, GA, USA*

*Dr. Radmil Polenakovik, Ss. Cyril and Methodius University, Skopje, MK*

*Professor Petko Ruskov, Sofia University, Sofia, Bulgaria*

*Professor Vojin Senk, University of Novi Sad, Novi Sad, Serbia*

*Dr. Jaka Vadnjal, GEA College for Entrepreneurship, Piran, Slovenia*

*Professor Colin Williams, University of Sheffield, Sheffield, United Kingdom*

---

**■ SCIENTIFIC COMMITTEE – Committee Members**

*Mr. Adi Kovacevic, WUS Austria, Graz, Austria*

*Mr. Anthony Gribben, European Training Foundation, Turin, Italy*

*Dr. Anna Sotiriadou, CITY-College, Thessaloniki, Greece*  
*Dr. Anton Constantin Micu, Bucarest, Romania*  
*Dr. Bozidar Lekovic, Faculty of Economy, Subotica, Serbia*  
*Mr. Bojan Lalic, Faculty of Technical Sciences, Novi Sad, Serbia*  
*Dr. Bobek Suklev, Faculty of Economy, Skopje, Macedonia*  
*Mr. Boris Curkovic, University of Tuzla, Tuzla, Bosnia and Herzegovina*  
*Dr. Christina Miariti, SEERC, Thessaloniki, Greece*  
*Mr. Darko Konjevic, Podgorica, Montenegro*  
*Dr. Delco Jovanoski, Faculty of Mechanical Engineering, Skopje, Macedonia*  
*Dr. Denise Fletcher, University of Sheffield, Sheffield, United Kingdom*  
*Ms. Efka Heder, European Training Foundation, Turin, Italy*  
*Dr. Elena Rodriguez-Falcon, University of Sheffield, Sheffield, United Kingdom*  
*Dr. Fuada Stankovic, Faculty of Law, Novi Sad, Serbia*  
*Mr. Herbert Pock, Graz, Austria*  
*Mr. Igor Medic, BIOS, Osijek, Croatia*  
*Dr. Igor Pavlin, GEA College, Ljubljana, Slovenia*  
*Dr. Ilija Cosic, Technical University, Novi Sad, Serbia*  
*Mr. Jack Bourke, University of Limerick, Limerick, Ireland*  
*Dr. Karl Hainz-Fiedler, SPICE, Berlin, Germany*  
*Dr. Karolj Kasas, Regional Chamber of Commerce, Subotica*  
*Dr. Kiril Anguelov, Technical University, Sofia, Bulgaria*  
*Dr. Klaus Schuch, ZSI, Vienna, Austria*  
*Dr. Konstantin Dimitrov, Faculty of Mechanical Engineering, Skopje, Macedonia*  
*Dr. Konstantin Petkovski, University St. Kliment Ohridski, Bitola, Macedonia*  
*Dr. Lenny Koh, University of Sheffield, Sheffield, United Kingdom*  
*Dr. Ljubica Shuturkova, University "Ss. Cyril and Methodius", Skopje, Macedonia*  
*Dr. Ljubomir Drakulevski, Faculty of Economy, Skopje, Macedonia*  
*Dr. Luke Pitaway, University of Sheffield, Sheffield, United Kingdom*  
*Mr. Martin Felix - Gajdusek, ASO Sofia, Sofia, Bulgaria*  
*Mr. Michel Richter, SENSI, Amsterdam, Nederland*  
*Dr. Martha Muhlburger, University of Leoben, Leoben, Austria*  
*Academic Nikola Klusev, MASA, Macedonia*  
*Dr. Nenad Penezic, Faculty of Technical Sciences, Novi Sad, Serbia*  
*Dr. Nikos Zaharis, SEERC, Thessaloniki, Greece*  
*Mr. Peter Perkonigg, Styrean Development Agency, Graz, Austria*  
*Dr. Ricardo Pinto, Stratagem Consulting International, Hamburg, Germany*  
*Dr. Slavica Singer, JJ Strosmaer University, Osijek, Croatia*  
*Academic Taki Fiti, Skopje, MASA, Macedonia*  
*Dr. Todor Kralev, Faculty of Tourism, Skopje, Macedonia*  
*Dr. Valentina Gecevska, Faculty of Mechanical Engineering, Skopje, Macedonia*  
*Dr. Vasyf Gerasymchuk, National Technical University of Ukraine, Kiev, Ukraine*  
*Dr. Velimir Stojkovski, University "Ss. Cyril and Methodius", Skopje, Macedonia*  
*Dr. Vera Zelenovic, Regional Chamber of Commerce, Novi Sad*  
*Dr. Vojin Senk, Faculty of Technical Sciences, Novi Sad, Serbia*  
*Dr. Viktor Stefov, Faculty of Natural Science, Skopje, Macedonia*  
*Dr. Vladimir Dukovski, Faculty of Mechanical Engineering, Skopje, Macedonia*  
*Dr. Yannick Du Pont, SPARK, Amsterdam, Nederland*  
*Dr. Zoran Anisic, Technical University, Novi Sad, Serbia*

---

**GOALS**

*The objective of ICEIRD Consortium is to establish an effective channel of communication between policy makers, government agendas, academic and research institutions and persons concerned with*

the latest research, scientific development and practice on innovation and regional development, with the following goals:

- ✦ To bridge the gap between academic and industry through applied research on technology, innovation and entrepreneurship and regional economic development
- ✦ To foster knowledge transfer and collaboration between the academic and industry sectors in emergent technology, system and model contexts
- ✦ To organize annual conferences/workshops to meet with members and participants and disseminate latest research and practice
- ✦ To publish results of projects in quality academic and professional journals, books, handbooks, proceedings, and reports.
- ✦ To generate funding from sources such as local government and research councils for furthering and developing new projects that could benefit the regional and country economy and industry by sharing of experiences and know-how between regions and countries
- ✦ To work in partnership with industry on specific entrepreneurial challenges, or innovative ideas
- ✦ To drive international research collaboration on projects related to innovation and regional development.
- ✦ To serve as the resources and expertise's hub on entrepreneurship and innovation by providing an ICEIRD consortium platform and a knowledge bank.
- ✦ To infuse and pump knowledge and expertise into improving the competitiveness of enterprises in developing countries.
- ✦ To be the first successful international network that enables exchange and transfer of knowledge, expertise and resources between developed and developing countries (the real global innovative chain)

---

## ■ BACKGROUND

The International Conference for Entrepreneurship, Innovation and Regional Development (ICEIRD) Consortium was formally established in 2008. It is a multi - disciplinary and cross-sectoral network crossing several streams of theory and practice, namely entrepreneurship, innovation, regional economic development and information systems. The ICEIRD Consortium was set-up with members from institutions jointly researching and collaborating in strategising/organising the annual ICEIRD conference and managing joint projects focused on the theory, policy and practice of entrepreneurship and innovation in particular as it pertains to information technologies. One of the higher concern features of the so-called European Innovation Paradox is the divide between academic research and policy-making, between thinkers and doers. The ICEIRD can become an authoritative reference in bridging this gap by developing analysis in the field of innovation and regional policy, based on high-level academic research, but without neglecting the lessons learnt by policy makers and professionals in the field. Thus establishing experiential feedback learning loops and cross fertilization among two communities which have lived too far away from each other for far too long, and in the European Union in particular.

---

## ■ SUBMISSIONS

Paper Submission - Academic papers accepted and presented at the conference will be published in the Conference Proceedings. Selected papers will be also published in a special issue of the International Journal for Innovation and Regional Development (IJIRD), Interscience Publisher Ltd. As well as full academic papers, the following submissions are welcomed and will be published in the Booklet of Abstracts:

- **Case Study Submissions** - Presentations from individuals or companies working in the field
- **Practitioner Contribution** - Contributions, either presentations or demonstrations, from individuals or companies working in the field.

- **Institutional Contribution** - Contributions, either presentations or demonstrations, from institutions working in the field (agencies, chambers, tehnoparks, incubators, municipal offices, etc.)

**Abstract details:** All submission types require an abstract up to 300 words in the first instance, to be received by 22 January 2010.

**Full paper:** Only required for academic paper submissions once the abstract has been selected, no more than 6-8 pages to be received 26 March 2010. Papers should be submitted as DOC. and PDF. files through Easy Chair conference system.

---

## ■ LOCATION

Novi Sad is located in the southern part of Europe, in Serbia and lies on the left bank of the river Danube. It is the second largest city in Serbia.. In contrast to many other European destinations, has the reputation, by full right, of a multinational, multicultural and multi-confessional metropolis in which all differences are seen as advantages. The witnesses to that are Novi Sad Theatre/Újvidéki Színház and University of Novi Sad with 19 faculties and specialized departments at which the lectures are held in languages of national minorities or were founded with that purpose. Still, there are so many other things that represent a daily, lively routine of Novi Sad. Novi Sad is quite sensitive to its bridges. 134 pontoon bridges have been constructed from 1720s until 1920s. The history of these bridges is another story, a story so special that sometimes Novi Sad was called "the town where river runs above the bridges". Novi Sad is a simple city, hospitable and open-hearted to all of its visitors, built by measure of a man. It is a city one gets to know and love easily, but also a place hard to forget and leave forever.

---

## ■ CONTACT

### **Dr Zoran Anisic**

University of Novi Sad  
Faculty of Technical Sciences  
Trg Dositeja Obradovica 6  
21000 Novi Sad, Serbia  
tel.: +381 21 485 2192  
fax.: +381 21 459 536  
e-mail: [info@iceird.org](mailto:info@iceird.org)

### **Danijela Gracanin**

University of Novi Sad  
Faculty of Technical Sciences  
Trg Dositeja Obradovica 6  
21000 Novi Sad, Serbia  
tel.: +381 21 485 2154



**The XI<sup>th</sup> INTERNATIONAL SYMPOSIUM  
"YOUNG PEOPLE AND MULTIDISCIPLINARY RESEARCH"**

**ISYPMR - 2009**

12 - 13 NOVEMBER 2009

TIMISOARA, ROMANIA

■ **ANNOUNCEMENT**

The SYMPOSIUM will be organised by the NATIONAL R&D INSTITUTE FOR WELDING AND MATERIAL TESTING – ISIM TIMIȘOARA, ASSOCIATION FOR MULTIDISCIPLINARY RESEARCH (ACM-V), UNIVERSITY "POLITEHNICA" OF TIMISOARA under de aegis of MINISTRY OF EDUCATION, RESEARCH AND INNOVATION.

Specialists from SERBIA, HUNGARY and BULGARIA will participate in the SYMPOSIUM together with the ROMANIAN specialists.

You are invited to participate at the XI<sup>th</sup> INTERNATIONAL SYMPOSIUM "YOUNG PEOPLE AND MULTIDISCIPLINARY RESEARCH".

■ **KEYWORDS:**

Scientific events, Multidisciplinary Research, Symposium, Scientific collaborations, Young People

■ **GENERAL INFORMATIONS – AIMS**

The aim of the SYMPOSIUM is to create the framework for the presentation, debate and publication of the valuable scientific results obtained by both the young members of ACM-V and from other regions, beside those from SERBIA, HUNGARY and BULGARIA.

The Organization Committee propose that the XI<sup>th</sup> SYMPOSIUM to be one of high scientific level and quality.

The criteria for the papers' estimation by the Scientific Committee are:

- ✚ interdisciplinary and multidisciplinary technical – scientific character
- ✚ high scientific level

✚ contribution brought to the solution of the proposed problem and/or development of the field.

You are invited to participate at the XI<sup>th</sup> INTERNATIONAL SYMPOSIUM "YOUNG PEOPLE AND MULTIDISCIPLINARY RESEARCH".

The participants are asked to fill-in and mail the Registration form to the Secretariat of the ASSOCIATION FOR MULTIDISCIPLINARY RESEARCH OF THE WEST ZONE OF ROMANIA (ACM-V) located at TIMISOARA, Bv. MIHAI VITEAZUL nr. 30 and also to mail an abstract of the paper in ENGLISH (200 words at the most) specifying the section.

**ORGANIZERS**

- ✚ NATIONAL R&D INSTITUTE FOR WELDING AND MATERIAL TESTING – ISIM TIMIȘOARA,
- ✚ ASSOCIATION FOR MULTIDISCIPLINARY RESEARCH (ACM-V),
- ✚ UNIVERSITY “POLITEHNICA” OF TIMIȘOARA
- ✚ BANAT’S UNIVERSITY OF AGRICULTURAL SCIENCES AND VETERINARY MEDICINE – TIMIȘOARA
- ✚ THE LOCAL COUNCIL OF TIMIȘOARA, TIMIȘOARA CITY HALL
- ✚ THE COUNTY COUNCIL OF TIMIȘ

under de aegis of

- ✚ MINISTRY OF EDUCATION, RESEARCH AND INNOVATION

**MODEL FOR PAPER’S ELABORATION**

- ❖ The paper should contain max. 6 pages, size A4 (with figures and tables included in the text, including bibliography), with an even number of pages;
- ❖ The paper should be edited on computer with Arial font, 12 pt. on size A4 with useful area of 24 cm × 16 cm (left, right and up 2.5 cm, down 3.0 cm);
- ❖ The pages should be numbered by pencil;
- ❖ The papers should be written in Word format;
- ❖ The title of the paper should be written with capital letters (14 pt. - Bold), centred;
- ❖ The paragraph title should be written with 12 pt. bold fonts and it might be centred.
- ❖ Graphic materials should be exposed on transparent slides or Power Point presentation,
- ❖ The presentation should take 10 minutes at the most

The paper will be transmitted on CD and listed in one copy.

An author can participate with two papers at the most.

**TOPICS**

The programme of the Symposium contains papers in Plenary Session on the topic: „PRIORITIES OF THE EUROPEAN SCIENTIFIC RESEARCH”

Papers in sections of the XI<sup>th</sup> INTERNATIONAL SYMPOSIUM “YOUNG PEOPLE AND

MULTIDISCIPLINARY RESEARCH” will on the following topics:

- ✚ TECHNICAL SCIENCES
- ✚ CHEMISTRY, PHYSICS AND MATHEMATICS
- ✚ BIOLOGY, AGRICULTURE AND ANIMAL SCIENCE
- ✚ HEALTH (HUMAN AND VETERINARY)
- ✚ ECOLOGY AND ENVIRONMENT PROTECTION
- ✚ SOCIAL AND HUMAN SCIENCES.
- ✚ ECONOMIC SCIENCES

**INTERNATIONAL SCIENTIFIC COMMITTEE**

- PROF. DR. AVRAM JECU – MEDICINE AND PHARMACEUTICS UNIVERSITY “VICTOR BABEȘ” TIMIȘOARA - ROMANIA
- PROF. DR. ENG. BARTZER ȘTEFAN – “POLITEHNICA” UNIVERSITY OF TIMIȘOARA - ROMANIA
- PROF. DR. BORȚUN CRISTINA – MEDICINE AND PHARMACEUTICS UNIVERSITY “VICTOR BABEȘ” TIMIȘOARA - ROMANIA
- LECT. DR. BUNOIU OCTAVIAN – WEST UNIVERSITY OF TIMIȘOARA - ROMANIA
- PROF. DR. ENG. BUTNARU GALLIA – UNIVERSITY OF AGRICULTURAL SCIENCE AND VETERINARY ACADEMY OF BANAT - USAMVB TIMIȘOARA - ROMANIA
- PROF. DR. ENG. CHIRIAC ADRIAN – WEST UNIVERSITY OF TIMIȘOARA - ROMANIA
- DR. COSTIȘOR OTILIA – INSTITUTE OF CHEMISTRY OF THE ROMANIAN ACADEMY TIMIȘOARA - ROMANIA
- DR. FARBAȘ NICOLAE – NATIONAL R&D INSTITUTE OF WELDING AND MATERIAL TESTING TIMIȘOARA - ROMANIA
- PROF. DR. ENG. HODUR CECILIA – UNIVERSITY OF SZEGED - HUNGARY
- PROF. DR. ENG. KILYENI ȘTEFAN – “POLITEHNICA” UNIVERSITY OF TIMIȘOARA - ROMANIA
- PROF. DR. ENG. KUZMANOVIC SINISA – UNIVERSITY OF NOVI SAD - SERBIA
- PROF. DR. ENG. MITELEA IOAN – “POLITEHNICA” UNIVERSITY OF TIMIȘOARA - ROMANIA
- PROF. DR. OSTAFE VASILE – WEST UNIVERSITY OF TIMIȘOARA - ROMANIA
- PROF. DR. ENG. POPA HORIA – “POLITEHNICA” UNIVERSITY OF TIMIȘOARA - ROMANIA
- DR. PURNHAUSER LASZLO – CEREAL RESEARCH NON-PROFIT COMPANY, SZEGED – HUNGARY
- READER DR. ENG. RUSU NICOLAE – FACULTY OF ENGINEERING HUNEDOARA - ROMANIA
- PROF. DR. ȚIBRU IOAN – USAMVB TIMIȘOARA - ROMANIA

**HONORY PRESIDENT**

PROF. DR. ENG. NICOLAE ROBU – RECTOR OF UNIVERSITY "POLITEHNICA" TIMIȘOARA

**PRESIDENT OF THE ORGANISING COMMITTEE**

LECTURER DR. ENG. FLAVIU FRIGURĂ ILIASA – UNIVERSITY "POLITEHNICA" OF TIMIȘOARA

**REGIONAL ORGANIZING COMMITTEE**

- LECT. DR. ENG. ALBU ADRIANA – UNIVERSITY "POLITEHNICA" OF TIMISOARA - ROMANIA
- LECT. DR. ENG. ALEXA VASILE – FACULTY OF ENGINEERING HUNEDOARA - ROMANIA
- LECT. DR. ENG. ANGHEL CORNELIA – UNIVERSITY "EFTIMIE MURGU" REȘIȚA - ROMANIA
- LECT. DR. ENG. ANISIC ZORAN – UNIVERSITY OF NOVI SAD - SERBIA
- DR. ENG. ATANASOV ATANAS – INSTITUTE OF AGRICULTURE AND SEED SCIENCE „OBRAZCOV CHIFLIK” RUSSE - BULGARIA
- LECT. DR. ENG. BIKIC SINISA – UNIVERSITY OF NOVI SAD - SERBIA
- READER DR. ENG. BIRIȘ SORIN – POLITEHNICA UNIVERSITY OF BUCHAREST - ROMANIA
- DR. BORA ALINA – INSTITUTE OF CHEMISTRY OF THE ROMANIAN ACADEMY TIMISOARA - ROMANIA
- LECT. DR. ENG. BORUZ SORIN – UNIVERSITY OF CRAIOVA - ROMANIA
- READER DR. ENG. BUNGESCU SORIN – TIBERIU – USAMVb TIMISOARA - ROMANIA
- ASSIST ENG. BUIANĂ GABRIEL – USAMVb TIMISOARA - ROMANIA
- DR. CRIȘAN MANUELA – INSTITUTE OF CHEMISTRY OF THE ROMANIAN ACADEMY TIMISOARA - ROMANIA
- ASSIST LECT. DR. ENG. DANCI OANA – USAMVb TIMISOARA - ROMANIA
- DIPL. PHYS. FARBAȘ VALERIA – ASSOCIATION FOR MULTIDISCIPLINARY RESEARCH IN THE WEST ZONE OF ROMANIA
- PROF. DR. ENG. GRUNEANȚU IOSIF – UNIVERSITY OF PETROSANI - ROMANIA
- LECT. DR. ENG. IMBREA ILINCA – USAMVb TIMISOARA - ROMANIA
- READER DR. ENG. KISS IMRE – FACULTY OF ENGINEERING HUNEDOARA - ROMANIA
- READER DR. NEGRUȚIU MEDA – MEDICINE AND PHARMACEUTICS UNIVERSITY "VICTOR BABEȘ" TIMISOARA – ROMANIA

- DR. NYARI TEREZIA – NATIONAL R&D INSTITUTE FOR ELECTROCHEMISTRY AND CONDENSED MATTER - ROMÂNIA
- LECT. DR. ENG. POPESCU IONEL – UNIVERSITY "AUREL VLAICU" OF ARAD - ROMANIA
- DIPL. ENG. PRICOP ANCA – USAMVb TIMISOARA - ROMANIA
- READER DR. PUTZ MIHAI – WEST UNIVERSITY OF TIMISOARA - ROMANIA
- LECT. DR. ENG. RAȚIU SORIN – FACULTY OF ENGINEERING HUNEDOARA - ROMANIA
- DR. ENG. ROSU RADU – ISIM TIMISOARA - ROMANIA
- LECT. DR. ENG. RACKOV MILAN – UNIVERSITATEA NOVI-SAD – SERBIA

**DEADLINES**

The deadline for mailing the abstracts, in which, it will be showed the personal contribution of the authors and the interdisciplinary character: JULY 17<sup>th</sup> 2009.

The Scientific Committee will analyse the abstracts and communicate to the authors until the 10<sup>th</sup> of SEPTEMBER 2009 which are the selected papers, with a view to the final elaboration.

The deadline for mailing of the complete papers, edited according to the annexed model and the CD until: OCTOBER 5<sup>th</sup> 2009

The publication in volume or on CD of the papers will be decided by the Scientific Committee following the analysis of the complete papers mailed in time, if these fulfill the technical-scientific criteria and the elaboration mode.

Any correspondence should be addressed to the secretariat of the SYMPOSIUM, located at the ASSOCIATION FOR MULTIDISCIPLINARY RESEARCH (ACM-V). Bd. MIHAI VITEAZUL nr. 30, 300222 TIMISOARA, ROMANIA, Tel. (+40) - 0256 - 491840, Fax (+40) - 0256 - 499149

**ISYPMR - 2009**

**The XI<sup>th</sup> INTERNATIONAL SYMPOSIUM**

**"YOUNG PEOPLE AND MULTIDISCIPLINARY RESEARCH"**

■ **INFORMATION - CORRESPONDENCE**

Any correspondence should be addressed to the secretariat of the Symposium, located at the ASSOCIATION FOR MULTIDISCIPLINARY RESEARCH (ACM-V).

BD. MIHAI VITEAZUL NR. 30,  
300222 TIMISOARA, ROMANIA

Tel. (+40) - 0256 - 491840

Fax (+40) - 0256 - 499149

Contact persons:

**Mr. Phys. Nicolae Farbaș Ph.D.**

E-mail: [nfarbas@isim.ro](mailto:nfarbas@isim.ro)

**Mr. Lect. eng. Sorin-Tiberiu Bungescu Ph.D.**

E-mail: [sobungi@yahoo.com](mailto:sobungi@yahoo.com)

**ISYPMR - 2009**

**The XI<sup>th</sup> INTERNATIONAL  
SYMPOSIUM**

**"YOUNG PEOPLE AND  
MULTIDISCIPLINARY RESEARCH"**



**ACTA TECHNICA CORVINIENSIS  
– BULLETIN of ENGINEERING**

copyright ©

**UNIVERSITY POLITEHNICA TIMISOARA  
FACULTY OF ENGINEERING HUNEDOARA**

**5, REVOLUTIEI**

**331128 – HUNEDOARA**

**ROMANIA**

<http://acta.fih.upt.ro>

---

## ***THE 3<sup>RD</sup> KUWAIT WASTE MANAGEMENT CONFERENCE & EXHIBITION***



***6<sup>TH</sup> – 8<sup>TH</sup> APRIL 2010  
KUWAIT***

---

### **■ OVERVIEW**

*The 3rd Kuwait Waste Management Conference & Exhibition will be held on 6 – 8 April 2010 at the Radisson SAS Hotel under the patronage of H.E. Dr. Fadel Safer, Minister of Public Works and State Minister of Municipal Affairs and with the support of Kuwait Municipality, Environment Public Authority and Public Authority of Industry.*

*The 3rd Kuwait Waste Management Conference & Exhibition is the region's definitive event dedicated to the waste industry. Now in its third year, the event is the leading industry forum for the latest waste technologies, solutions and products.*

*This 3-day event will feature valuable insights and practical experiences. Several hundred participants are expected to attend from Kuwait and nearby regions and countries, along with other international experts. With multiple technical sessions focused on municipal, industrial and medical waste management challenges, the event promises a unique opportunity for delegates to gain insights into waste management solutions, listen to regional and international case studies and network with their peers.*

### **■ PROGRAM:**

*Kuwait Waste Management Conference & Exhibition will address all areas of waste management, including:*

- ✚ Solid waste management*
- ✚ Construction and demolition waste management*
- ✚ Industrial waste management*
- ✚ Waste management for oil, gas and petrochemical industries*

- ✚ *Hazardous waste management*
- ✚ *Medical waste management*
- ✚ *Wastewater management*
- ✚ *Recycling Systems*
- ✚ *Material Recycling*
- ✚ *Landfill technologies*
- ✚ *Composting*
- ✚ *Waste-to-Energy*
- ✚ *Waste management policy, financing, planning and regulation*

If you wish to participate at the event as a speaker and have suggestions for the program, email us here [info@kuwaitwaste.com](mailto:info@kuwaitwaste.com)

---

**■ EXHIBITION:**

*An exhibition will be held in conjunction with the technical sessions within the conference venue. The exhibition is intended to provide an opportunity for companies, consulting and research organizations to display and demonstrate their products and services related to the subject of Recycling & Waste Management and other associated services. Interested organizations are encouraged to participate either by sponsoring the event or by taking part in the exhibition.*

---

**■ WORKSHOP: HEALTHCARE WASTE WORKSHOP - ADVANCED LEVEL**

*The effective management of healthcare waste is of vital importance to the health care sector and the people in all countries, who need to be assured that such wastes are managed and disposed of properly.*

*The different categories of waste normally generated from a health care setting are non-risk/non-hazardous, solid waste (household waste) as well as risk/hazardous waste such as infectious waste, sharps, pharmaceuticals, chemicals and other potential dangerous waste streams. Included in the domestic waste is also 'green waste' from maintenance of grounds, and construction and demolition wastes from building activities.*

*Transmission of disease occurs mainly through injuries from contaminated sharps and through inhalation of bio-aerosols. Besides tuberculosis (TB), blood borne diseases - like hepatitis B (HBV), hepatitis C (HCV), and the human immunodeficiency virus (HIV) - are infections of particular concern. Toxic risks arise among others from reagents (particularly laboratory reagents), drugs, and mercury thermometers (CEC, 1993).*

*The personnel responsible for health care waste management, i.e. for waste minimisation, collection, transport, storage, treatment and disposal, will require access to relevant professional advice and the implementation of a sound management system adequate for the purpose. Risk assessment is required in the contexts of the protection of staff and the protection of the environment.*

*Due to the changes in health care processes, the quantity and quality of healthcare waste is changing. The volume of waste generated is steadily raising and materials are getting more toxic. Those responsible for health care waste are increasingly challenged to investigate further the management of health care wastes. The aim, where possible, should be to substantially reduce the volume of waste. Special consideration should be given to hazardous waste, because of its higher risks and the cost intensive specialist treatment and disposal. In particular, sound and practical systems of segregation are required.*

*This advanced level course is not intended for trainees without previous knowledge in healthcare waste management. The advanced training course will especially deal with the following subjects and waste streams:*

- *Pharmaceutical waste*
- *Photochemical waste*
- *Cytotoxic waste*
- *Other chemical waste*

- Contracting & pricing of waste services
- Occupational health & safety
- External transportation of waste

■ **TRAINING COURSE:**

*The overall goal of this training course is to train healthcare and paramedical staff in the principles of advanced healthcare waste management and to introduce better management processes.*

**Objectives of the training course**

*The main objective of the training is to increase the know-how of responsible persons for healthcare waste management in for waste management in their hospital. The participants will learn how to plan, set up and independently run advanced healthcare waste management systems of a health institution. After the course, the employees will know how to deal with more complex waste streams and how to reduce occupational health impacts by hazardous waste. They will know how to react in case of emergencies and injuries and how to use more advanced waste management tools.*

**Target Audience**

*The training is targeting employees of the middle or higher management level of a healthcare institution who are responsible for the monitoring and management of the safe handling of healthcare waste. It is expected that the participants have a basic knowledge in healthcare waste management.*

**Tutorial Design and teaching method**

*The course is a mix of informative theoretical lessons and interactive workshops (lectures/presentations). The lessons are based on simulations, questions, exercises, and practical demonstrations undertaken by qualified trainers to make learning enjoyable and to encourage a high level of knowledge retention. Following the training, participants' performance will be evaluated.*

**Topics covered**

*The tutorials are practical orientated and covers a wide range of topics, including:*

- ✚ Tasks and responsibilities of an healthcare waste officer
- ✚ Job description, SOP, MSDS, etc. for healthcare waste management
- ✚ Advanced planning of modern healthcare waste systems
- ✚ Recycling of hazardous and non-hazardous waste
- ✚ Management of complex waste streams including
  - Pharmaceutical waste
  - Chemical waste
  - Cytotoxic waste
- ✚ Photochemical waste
- ✚ Contracting of waste treatment & disposal
- ✚ External logistic aspects
- ✚ Management methods for different types of waste
- ✚ Development and implementation of waste management plans
- ✚ Alternative treatment methods for bio-hazardous waste

■ **CALL FOR PAPERS:**

*Authors are invited to submit an abstract of the proposed paper in English or Arabic. It should state clearly the objectives, subject matter and conclusions to be presented in the full paper. Selection of papers will take account of originality, relevance, and likely interest to delegates.*

*Papers should be of technical nature and we recommend that authors take an exhibition stand should they wish to support their presentations with commercial material.*

■ **ABSTRACT SUBMISSION:**

*Send abstracts via email to: [program@kuwaitwaste.com](mailto:program@kuwaitwaste.com)*

*Abstracts should be submitted in a Word Document file or PDF, maximum one A4-page in length. The abstract should contain a full title, the names and addresses of the authors, and contact person details.*

*Please include full name, address, email address and phone number for the contact person and lead author.*

---

■ **DEADLINES:**

- ✚ Abstracts Due: *December 31, 2009*
- ✚ Abstract Acceptance Due: *January 15, 2010*
- ✚ Final Version Due: *February 15, 2010*
- ✚ Conference and Exhibition: *April 6th - 8th, 2010*

*It may be possible to accept a small number of late submissions.*

---

■ **CONFERENCE LANGUAGES:**

*The official conference languages are English and Arabic. Papers, visual materials, and other documents will be presented in the English or Arabic languages.*

*Correspondence regarding all aspects of the abstracts or technical papers should be sent preferably by e-mail to the Technical Committee at [program@kuwaitwaste.com](mailto:program@kuwaitwaste.com).*

---

■ **SHORT COURSES:**

*Short courses will be offered for an additional cost in conjunction with the Conference. The short course topics will be announced in our next mailing. Any company specialized in a subject matter and wishes to propose a course should contact the Technical Committee Chairman.*

---

■ **FOR MORE DETAILS:**

*Please Contact The Technical Committee Kuwait waste Management Conference & Exhibition*

- ✚ P.O. Box 1242 Dasman, 15463 Kuwait
- ✚ Tel: +965 24342828
- ✚ Fax: +965 24330809
- ✚ E-mail: [program@kuwaitwaste.com](mailto:program@kuwaitwaste.com)



---

**GENERAL GUIDELINES  
FOR PREPARATION OF MANUSCRIPTS  
FOR REVIEW IN  
ACTA TECHNICA CORVINIENSIS  
– BULLETIN OF ENGINEERING**

---

---

■ **Abstract:**

a maximum 100 words abstract will be written, simple spaced, in **ENGLISH**

---

■ **Keywords:**

a maximum 10 representative words for the paper

---

---

■ **THE TEXT**

The submitted manuscript must be content **INTRODUCTIVE NOTES (INTRODUCTIONS)**, follow by the **METHODOLOGY**, the **PRELIMINARY RESULTS** or the **FINAL RESULTS**, and, in final, the **CONCLUSIONS** about the presented notes.

Also, the paper included the **ABSTRACT**, **KEYWORDS**, and **REFERENCES**.

The conclusions must be clear, relevant and must be indicate some the empirical, theoretical, methodological or scientific aspects of the research, and the author's contributions, or the future preliminaries of our research. It will publish empirical, theoretical and methodological articles.

---

■ **THE TABLES, FIGURES, GRAPHS AND EQUATIONS**

Tables and Figures should be numbered, titled and the resource should be mentioned below them. Photographs in the text are preferable to be in black and white, but must be clear, with a high contrast. Under each figure there will be typed, centered, "Figure X. Name of the figure".

Tables will be part of the text, designed as "Table y. Name of the table", written above the table, centered.

The equations will be inserted in the text – left aligned – and will be numbered with Arabian figures, in round brackets, right aligned. Before and after the equation a blank line will be left.

---

■ **SUBMISSION OF MANUSCRIPTS**

The original of the technical paper will be sent through e-mail as attaché document (\*.doc, Windows 95 or higher).

---

---

■ **ACKNOWLEDGMENT**

---

*If is necessary, please write yours works based research [Title, Contract no., Team, Year etc]*

---

■ **REFERENCES**

---

[1] *AUTHORS. YEAR. TITLE OF REFERENCE, JOURNALS NAME, VOLUME, PAGES*

[2] *AUTHORS. YEAR. TITLE OF BOOK, EDITING HOUSE*

[3] *AUTHORS. YEAR. TITLE OF REFERENCE, CONFERENCE NAME, VOLUME OR PROCEEDING, PAGES*

---

■ **AUTHORS & AFFILIATION**

---

<sup>1</sup> *NAME SURNAME*

<sup>2</sup> *NAME SURNAME*

<sup>1</sup> *DEPARTMENT, FACULTY, UNIVERSITY, COUNTRY*

<sup>2</sup> *INSTITUTION OR COMPANY, COUNTRY*



**ACTA TECHNICA CORVINIENSIS**  
**– BULLETIN of ENGINEERING**

copyright ©

**UNIVERSITY POLITEHNICA TIMISOARA**  
**FACULTY OF ENGINEERING HUNEDOARA**  
**5, REVOLUTIEI**  
**331128 – HUNEDOARA**  
**ROMANIA**

<http://acta.fih.upt.ro>



***ACTA TECHNICA CORVINIENSIS***  
***– Bulletin of Engineering***  
*copyright © UNIVERSITY POLITEHNICA TIMISOARA*  
*FACULTY OF ENGINEERING HUNEDOARA*  
*5, REVOLUTIEI*  
*331128 – HUNEDOARA*  
*ROMANIA*  
<http://acta.fih.upt.ro>

*Scientific supplement of*  
***ANNALS of FACULTY ENGINEERING HUNEDOARA***  
***– INTERNATIONAL JOURNAL of ENGINEERING***  
*ISSN: 1584-2665 [print]*  
*ISSN: 1584-2673 [CD-Rom]*  
*copyright © UNIVERSITY POLITEHNICA TIMISOARA*  
*FACULTY OF ENGINEERING HUNEDOARA*  
*5, REVOLUTIEI*  
*331128 – HUNEDOARA*  
*ROMANIA*  
<http://annals.fih.upt.ro>





*fascicule 4*  
[ October - December ]  
TOME II [2009]