

¹Radko Petrov MIHAJLOW, ²Lazar Georgiev PANAIOTOV,
³Svilen Hristov STOIANOV, ⁴Desislava Palcheva MIHAJLOVA

SIMULATION MODELING AND PROCESSING THE DATA RECEIVED IN MEASURING WASTE BIOMASS

¹⁻⁴: Technical University of Varna, Dobrudzha College of Technology, Dobrich, BULGARIA

Abstract: The object of current investigation is a device designed to measure the biomass waste mounted directly on a harvester. An original measuring gadget based on a four linked planar mechanism is proposed and examined by use of a prototype equipped with sensors. Experiments conducted under real conditions demonstrate the operability of the device. Information on the amount and parameters of biomass waste is digitally processed, visualized and stored in computer memory. This is realized by use of a proper software platform implying an original processing algorithm. The results of experiments are reported and discussed below. Notes on further studies in this direction are made.

Keywords: biomass, measurement, planar mechanism, averaging

INTRODUCTION

Current study focuses on the collection of optimal and precise information about the biomass wasted at the time of harvesting. Still on field, together with the data issued from the contemporary harvesting machinery it is important to know the amount of biomass waste (BMW). The last is considered a valuable product, secondary resource, which can be used in the agricultural sector, particularly as a food or green manure in stock-raising and crops. It can also be implemented in the production of heat and energy [3].

This investigation envisions data processing and real time measurement of BMW produced immediately after the harvester. An original technique for monitoring and measurement the amount of BMW is proposed. It takes into consideration the fact that the biomass waste obtained at the time of cereals harvesting actually represents a layer of cornstalks forming a dynamic flow with fixed width and variable height. Respectively, the common principle for the level determination over certain surface [1, 2, 5] is applied.

The kinematics of the mechanical device used as a primary transformer, sensor for the BMW flow height is observed by means of a simulation approach.

Main task of the current study is to demonstrate an effective technique for collection and processing sensor data in real time in order to obtain the amount of BMW.

EXPERIMENTAL

The investigated simulation model, created using the SolidWorks software [7], is shown in Figure 1. It is based on the kinematic scheme of a four linked planar mechanism, namely slotted-link mechanism. The specific movement of the assembly is characterized by an equation derived after kinematic analysis. The equation represents the relation between the input and output parameters in the form of a transfer function, [4]:

$$\cos \alpha_1 = 0,877 \cos \alpha_2 - 0,14 \quad (1)$$

where the angles α_1 , α_2 are specified according to Figure 1 and the constants are empirically determined from the prototype created in [4].

The sensor operates on the following principle: the BMW flow is the one that moves the part called "Silencer" herein - this is considered the inlet of the device. The next parts named "Roll" and "Arm" is responsible for the angular turning of the slider of the potentiometric "Sensor" - the last is considered to be the outlet of the mechanism. Any change of the angle α_2 is registered by a sensor, mounted on top of the device, which turns it into a voltage signal. Afterwards, the measured signal is recorded and processed to obtain the final characteristics. For the purpose a specialized program is applied. In its interface the signal can be visualized in analog and digital form. Thus, a real time measurement of the necessary parameters is performed. The numerical transformations of the recorded signal are executed in seconds.

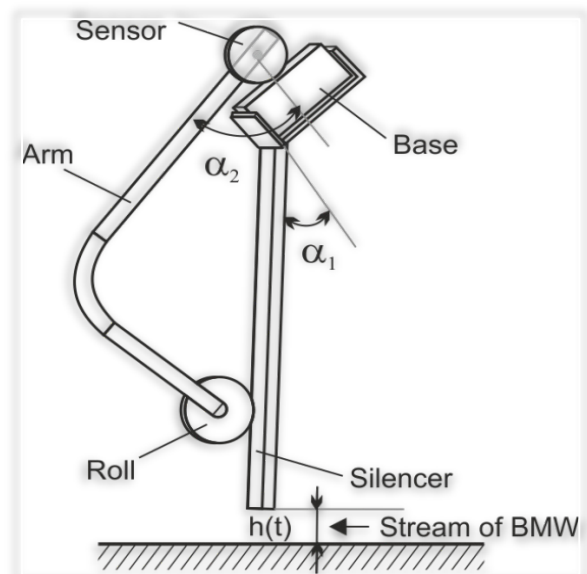

Figure 1. Simulation model of the device used as a BMW level sensor

An original program is created for the particular investigation based on the software platform LabVIEW [6]. The relevant algorithm is shown in Figure 2.

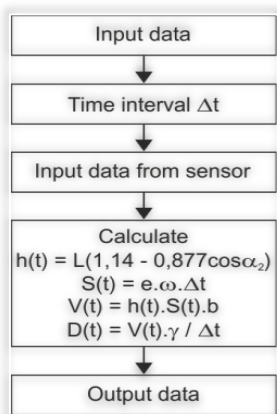

Figure 2. Algorithm

The following constants are initially set as input data for the particular measurement of the amount of BMW:

- Δt – period of measurement in which the sensor signal is measured (it is set to correspond the period value in the transforming program);
- b – width of the BMW flow (measured on the harvester, [8]);
- ω – angular velocity and eccentricity e of the straw-trailer crankshaft (measured on the harvester for once);
- L – length of the part used as a „Silencer“ for the moving waste biomass (Figure 1);
- γ – density – relative weight of the particular BMW.

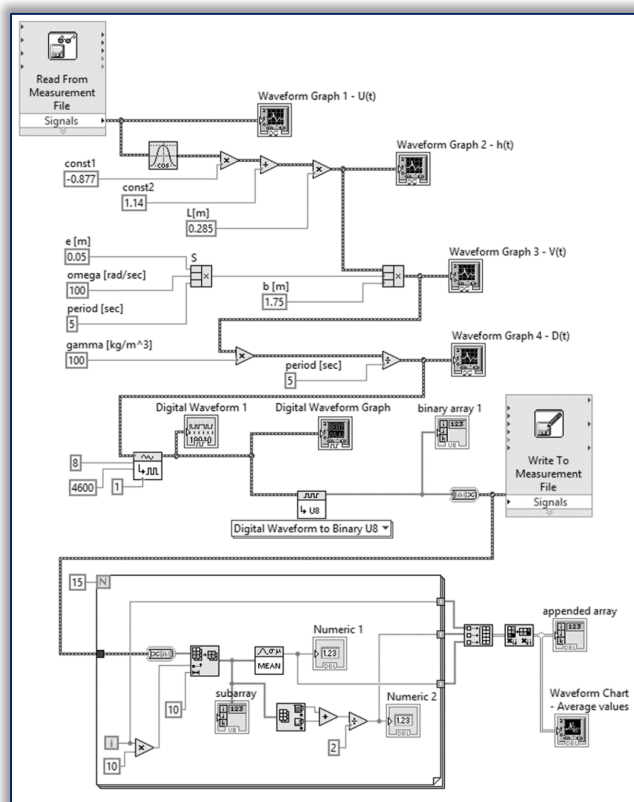

Figure 3. Block diagram of the application program in the LabVIEW environment

Figure 3 shows the block diagram of the main application program. At the beginning there is a proper virtual instrument (VI) for reading the information obtained from the sensor.

The final measurement data file (Figure 4) is saved in the required form for processing in LabVIEW. The results from data transformation are visualized in a Front Panel. The Waveform Graph 1 represents the initial analog signal (Figure 5a). As mentioned, data are manipulated by entering specific constants and the necessary arithmetic operations by means of specific VIs. Subsequently several time depending functions are calculated: the current values of $h(t)$ function (Figure 5b), which is the variable BMW height reflecting the change of the angle α_2 ; the values of the distance $S(t)$ function (Figure 2) within the period Δt ; the volume $V(t)$ (Figure 5c), as well as the calculated amount $D(t)$ of BMW (Figure 5d).

RESULTS AND DISCUSSION

The experimental data obtained from the sensor showing the change of the angle α_2 are displayed in Figure 4.

No	Time	DC/AC	Value	Unit
1	15:32:24	DC	12389,00	V
2	15:32:29	DC	11658,00	V
3	15:32:34	DC	13119,00	V
4	15:32:45	DC	15311,00	V
5	15:32:49	DC	22586,00	V
6	15:32:55	DC	45566,00	V
7	15:32:59	DC	22920,00	V
8	15:33:04	DC	17441,00	V
9	15:33:09	DC	12328,00	V
10	15:33:14	DC	42644,00	V

Figure 4. Experimental data in Excel form

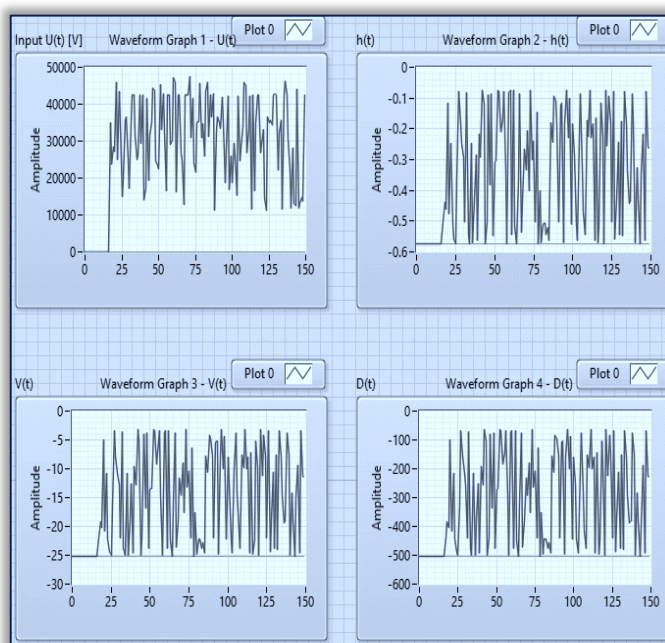

Figure 5. Waveform Graphs in the application environment of LabVIEW: a) analog signal from the potentiometric sensor; b) analog signal corresponding to the variable height $h(t)$ of the BMW stream; c) BMW volume $V(t)$; d) amount $D(t)$ of BMW

It should be noted that the values of the $D(t)$ function are additionally processed in order to be more appropriate for the final assessment. In a sub-program (the last section in Figure 3) a loop function is used to divide all data in arrays of 10 consequent samples. The array values are then averaged for each array subset. This operation is executed in a number of iterations. The final result is represented in Figure 6.

Two approaches have been applied to obtain the average amount $D(t)$. The first one implies a VI for mean value (Numeric 1 in Figure 3) and the second one follows the equation below:

$$D_{av} = \frac{\sum_{i=1}^{10} D_{min} + \sum_{i=1}^{10} D_{max}}{2} \quad (2)$$

As seen in Figure 6 the final curve of the averaged $D(t)$ function grounded on (2) has less fluctuations.

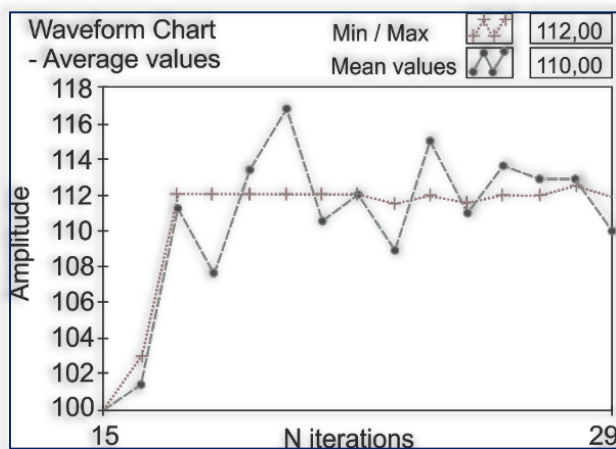

Figure 6. Average values for the amount of BMW

The average amount of 112 kg/m³ straw fits well the corresponding values obtained from relevant BMW investigations [9, 10].

CONCLUSIONS

A simulation model was constructed in the SolidWorks interface (Figure 1) which supplied additional information about the kinematics of the sensor device.

The final values for the volume and amount of biomass waste resulted immediately from an original application program in LabVIEW (shown in Figure 6). They correspond in maximum extent to the initial experimental data and relevant assessments of straw parameters.

Furthermore, a study on the relationship between both parameters, amount and surface of BMW, is to be performed. It will provide precise information about the amount of biomass waste at the end of the harvesting period.

Acknowledgement

The authors wish to acknowledge Bulgarian Ministry of Education and Science and Technical University of Varna for the financial support under the Project NP24/2016.

References

[1.] Asenov: Measuring flow of fluids (in Bulgarian), Sofia, Bulgaria, Technical University of Sofia, 2007.

- [2.] Kremlevskij, P.: Flow meters and devices for measuring quantities (in Russian), Leningrad, Mashinostroene, 1975.
- [3.] Krisnawati, A. and Muchlish, A. M.: Variability of Biomass and Harvest Index from Several Soybean Genotypes as Renewable Energy Source, www.sciencedirect.com, The 3rd Indo-EBTKE ConEx 2014, Indonesia, Energy Procedia65, pp. 14-21, 2015.
- [4.] Panaiotov, L.: Device for measuring the parameters of waste biomass obtained from the harvest of cereals (in Bulgarian under print), Ruse, Bulgaria, Technical papers of the Ruse University, 2016.
- [5.] Reyns, P., Missotten, B., Ramon, H. and De Baerdemaeker, J.: A Review of Combine Sensors for Precision Farming, Precision Agriculture (manufactured in the Netherlands), vol. 3, pp. 169 – 182, 2002.
- [6.] Shiralkar, M.: LabVIEW Graphical Programming Course, Collection Editor: National Instruments, on-line: <http://cnx.org/content/col10241/1.4/>, Rice University.
- [7.] SolidWorks – general course (in Bulgarian), Sofia, Bulgaria, TechnoLogika Ltd., 2004.
- [8.] <http://www.agrister.com/combiners/claas-medion-340>
- [9.] http://nd-international.com/onewebmedia/Strawbale_Dom-zajiveene.pdf
- [10.] <http://ires.bg/straw.php>



ISSN: 2067-3809

copyright © University POLITEHNICA Timisoara,
Faculty of Engineering Hunedoara,
5, Revolutiei, 331128, Hunedoara, ROMANIA
<http://acta.fih.upt.ro>