



1-Gelu Ovidiu TIRIAN

## ROBOTIC ARM FOR AUTOMATED COLORED OBJECT SORTING

<sup>1</sup>University Politehnica Timisoara, Faculty of Engineering Hunedoara, Hunedoara, ROMANIA

**Abstract:** This paper presents aspects related to the design, construction and operation of the mechanical structure and the action of an anthropomorphic robot with 4 degrees of freedom and prehensive mechanism. The robotic arm is equipped with a color sensor and several servomotors, is completely autonomous and has the ability to sort different color objects. Depending on the color of each object, it moves to a predetermined position and catches the object which is a randomly chosen color by the operator, rotates and positions over the color sensor, depending on the value returned by the sensor, inserts it into one from the red, green or blue boxes on the stand. Robot programming is done using the Arduino software.

**Keywords:** robotic arm, color sensor, Arduino, servomotors, programming

### INTRODUCTION

One of the first definitions given to the robot takes into account that it is a device that mimics man to a certain extent, either as a form or as a means of action. Thus, the robot is defined as an automatic mechanism that can substitute man for some operations, being able to modify its execution cycle by photoelectric detection, electronic brain, servomotor, etc. [1],[2],[3]

There are, of course, other definitions for industrial robots, of which:

- » The Japan Industrial Robots Association's definition - Japan Industrial Robot Association (JIRA) shows that the robot is a versatile and flexible device that offers movement functions similar to those of human limbs or whose movement functions are commanded by sensors and its own means recognition;
- » Definition of the UK Robot Association - The BRA (British Robot Association) shows that the robot is a reprogrammable device designed for the manipulation and transport of parts, tools, or other means of production by variable movements programmed to perform the specific manufacturing tasks;
- » The Robot Institute of America (RIA) - Robot Institute of America, says that the robot is a reprogrammable multifunctional manipulator designed to move materials, parts, tools, or other

specialized devices through programmed variable motions to perform different tasks.

The robot is a reprogrammable device designed for handling and transporting parts, tools, or other means of production by variable programmed movements to perform the specific manufacturing tasks [4-6].

From the above definitions, the following features of the industrial robots come to light [7,10]:

- » they are designed to perform mainly handling, displacement and transport
- » operations requiring speed and accuracy but for limited forces;
- » they are equipped with several degrees of freedom (between 2÷6) so that they can perform complex operations, each movement being controlled by the driving unit;
- » are autonomous, functioning without systematic human intervention;
- » they are equipped with a reprogrammable memory capable of conducting equipment necessary to perform operations that can be changed by changing the initial program;
- » they are endowed with a very low logic capacity, with which they can perform tests and choose between two alternatives, as well as change approval signals with other devices [6,7,10].

The technical characteristics of industrial robots include: dimensions, achievable travel values, precision, repeatability, freedom of movement, type of drive, robot

weight, workspace volume, command and control system capability, speed, transportable load, working conditions, to have several working arms [5,8].

**MECHANICAL STRUCTURE AND ROBOT FUNCTION**

This robot arm is completely autonomous and is designed to sort different objects according to color. The robot has 4 degrees of mobility and a prehension mechanism that helps him make complex moves.

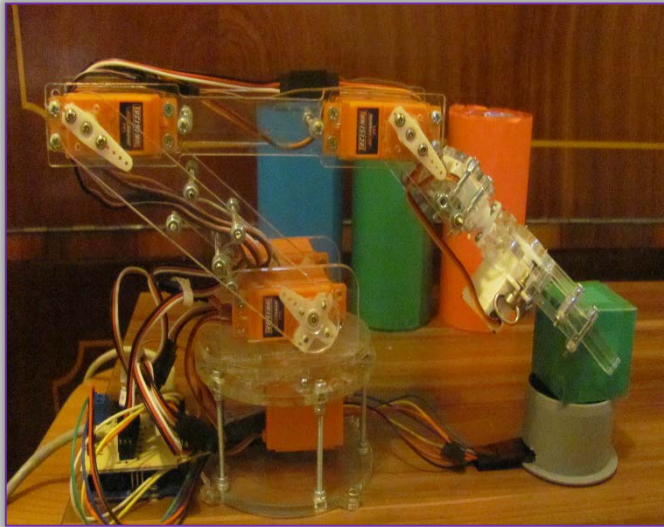

Figure 1. Mechanical structure of robot

It is made of 4 mm plexiglass, cut on a CNC laser machine, and is commanded by an Arduino Uno development board.

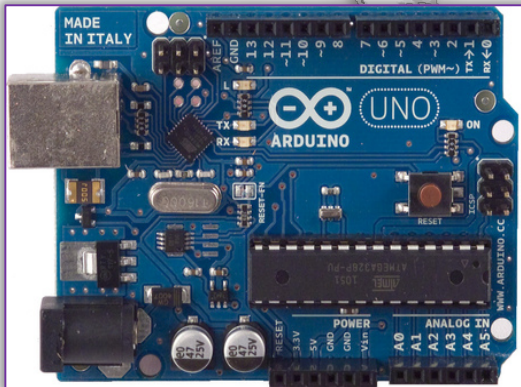

Figure 2. Arduino UNO



Figure 3. Colour sensor

Arduino UNO is an open-source processing platform based on flexible and simple software and hardware. It consists of a small platform (6.8 cm / 5.3 cm - in the most common version) built around a signal processor and is able to retrieve data from the environment through a series of sensors and perform actions On the environment through lights, motors, servomotors, and other types of mechanical devices. The processor is able to run written code in a programming language that is very similar to C ++ [2,9].

They used:

- » 5 servo motors: Servo Analog HK15138 Standard to control the base, shoulder, elbow and forearm,
  - » 2 Servo HK Servo HK 2.5 kg / 0.14 s Analog Micro to control the wrist and gripper
  - » for color sensor [2] 3 LEDs of 5mm red, green and blue were used, and for reading 5mm light-dependent light resistors (LDR) (Figure 5) [10], [11].
- The color scheme of the color sensor is shown in Figure 4, and the Shield electrical diagram in Figure 5.

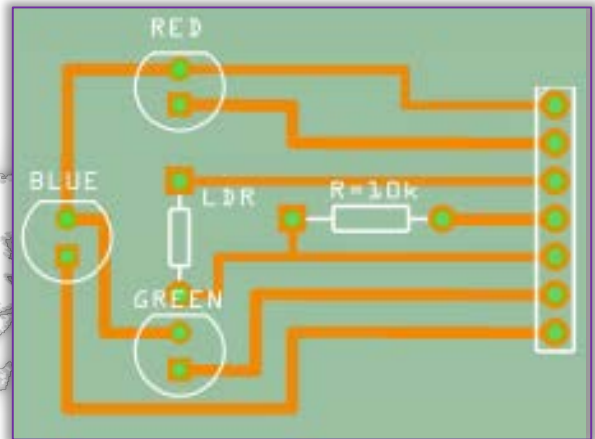

Figure 4. Electric scheme of colour sensor

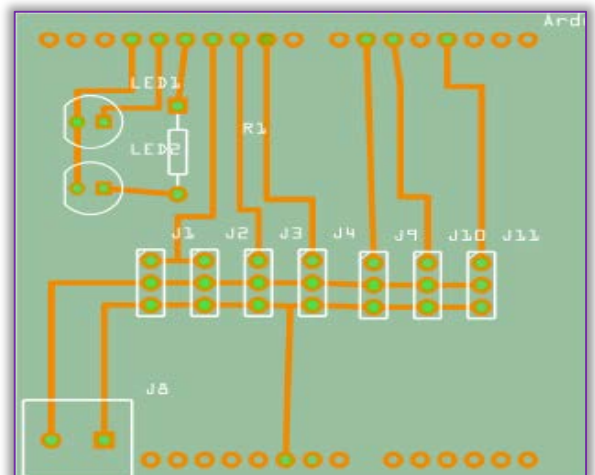

Figure 5. Shield

The LEDs are linked to the digital pins 4,7 and 8, and the photoresist at Arduino UNO's A0 pin (signal input pin). The shield linking the Arduino and the motors is shown in Figure 5 and is powered by a 6V voltage source.

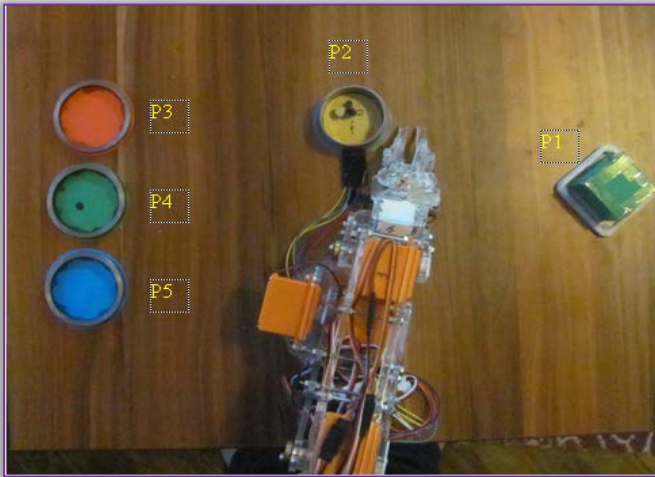

Figure 6. Robot functioning

The robot moves to the right in a predetermined P1 position and catches the cube that has a random color chosen by the operator, rotates and positions above P2 sensor. Depending on the value returned by the sensor [11], it puts it in one of the left, red, green or blue (P3, P4 or P5) left boxes.

### SOFTWARE IMPLEMENTING

The language used for correct operation is similar to C++ and is called Arduino. The following window is a programming editor used only for Arduino development boards. For this, you must enter the tools menu and choose the plaque you are working with, and the selected computer port [8, 9].

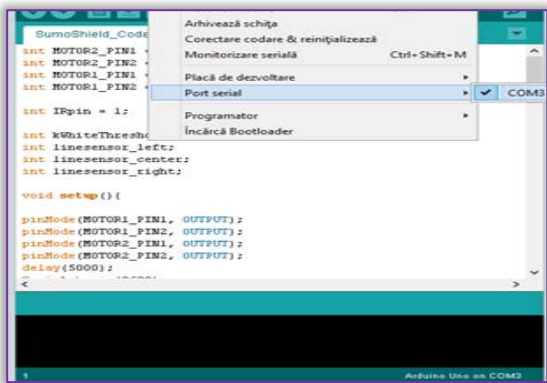
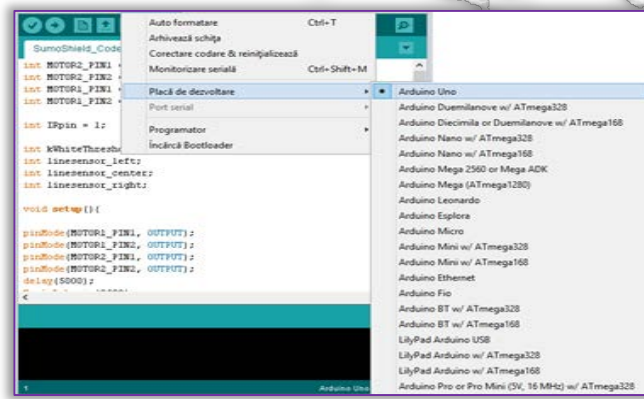



Figure 7. Arduino development board and selection of computer port

Any written program should be checked with the button  which checks for errors in the program structure, and by displaying the "Done compiling" message, the program can be run by pressing the upload button  which sends instructions via the COM3 port to the microcontroller, which processes and sends them to the output pins [9]. Here are some screens with the program code lines.

```
RoboCol
digitalWrite(led,HIGH);
delay(3000);
}

int sensor(void)
{
  int redv,albv,grev;
  int minc;
  int marcel;
  //ValCamera=analogRead(0);
  //Serial.println("Camera:");
  //Serial.println(ValCamera, DEC);
  //delay(6000);
  digitalWrite(red,HIGH);
  delay(200);
  redv=analogRead(0);
  digitalWrite(red,LOW);
  digitalWrite(alb,HIGH);
  delay(200);
  grev=analogRead(0);
  digitalWrite(alb,LOW);
  digitalWrite(gre,HIGH);
  delay(200);
  albv=analogRead(0);
  digitalWrite(gre,LOW);
  Serial.println("ROSU:");Serial.println(redv,DEC);
  Serial.println("VERDE:");Serial.println(grev,DEC);
  Serial.println("ALBASTRU");Serial.println(albv,DEC);
  minc=1025;
}
```

Figure 8. Program code lines

### CONCLUSIONS

This paper presents an application to sort colored objects with a robotic arm. We have a robotic arm which picks different colored cubes and sorts them placing in different locations. The color recognition is made using a color sensor.

The robotic arms are widely used in the industry, but most of them are used in a PTP (Point To Point) trajectory, the moves are learned previously by the robotic arm. Very few robots in the industry are programmed to be smart, or to make decisions. In the future to completely replace the humans with robots, we need robotic arms which can make decisions. One example for a robotic arm can be a robotic arm which can sort objects by color. This can be used in many factories, by example can be used in a pencil factory.

### References

- [1.] Barabás T., Vesselényi T., "Conducerea și programarea roboților industriali", Editura Universității din Oradea, 2004.
- [2.] Dumitriu A., Bucșan C., Demian T., "Sisteme senzoriale pentru roboți", Editura MEDRO, București, 1996.Laumond J.P., "Robot motion planning and control", Springer-Verlag, London, U.K., 1998.
- [3.] Gacsádi A., „Bazele roboticii”, Editura Universitatii din Oradea, 2008
- [4.] Ivanescu Mihai, „Robotica”, Editura Universitaria, 1995





- [5.] Ivanescu Mihai, "Roboți industriali", ed. Craiova, 1994.
- [6.] Ispas Victor, „Roboți pentru aplicații speciale”, Editura Dacia, 2001
- [7.] Iovine J., Robots, androids and animatrons”, McGraw-Hill, USA, 2002.
- [8.] Tirian G. O., “Automation of a warehouse by means of a robotic arm” - Annals of Faculty Engineering Hunedoara – International Journal of Engineering Tome XI, Fascicule 4, 2013.
- [9.] Tirian G. O., “Maze solving mobile robot”, Annals of Faculty Engineering Hunedoara, International Journal of Engineering, Tomul XIII, Fasc.4, 2015.
- [10.] Tirian G. O., “ Robotică”, Editura Politehnica Timisoara, 2013.
- [11.] Wu Wei, et. all, „An automatic method of location for number-plate using color”, features, Image Processing, 2001, Proceedings, International Conference on, Thessaloniki, Greece, Greece, 2002.



**ISSN:2067-3809**

copyright ©  
University POLITEHNICA Timisoara,  
Faculty of Engineering Hunedoara,  
5, Revolutiei, 331128, Hunedoara, ROMANIA  
<http://acta.fih.upt.ro>

